

The text of the EU-Honduras FLEGT VPA is made public here exclusively for information purposes. The text presented in this document is the text at the end of the negotiations conducted by the European Commission. It will be subject to legal revision in order to verify the internal consistency and to ensure that the formulations of the negotiating results are legally sound. It will be transmitted to the Council for its signing and, following assent of the European Parliament, conclusion. This text is therefore not binding under international law.

## **VOLUNTARY PARTNERSHIP AGREEMENT**

### **between the European Union and the Republic of Honduras on forest law enforcement, governance and trade in timber products to the European Union**

THE EUROPEAN UNION, hereinafter referred to as 'the Union',

and

THE REPUBLIC OF HONDURAS, hereinafter referred to as 'Honduras',

hereinafter referred to together as 'the Parties',

**CONSIDERING** the relationship between the Union and Honduras particularly in the context of the Association Agreement between the European Union and its Member States, of the one part, and Central America, of the other part, signed in 2012;

**CONSIDERING** the Political Dialogue and Cooperation Agreement between the European Community and its Member States, of the one part, and the Republics of Costa Rica, El Salvador, Guatemala, Honduras, Nicaragua and Panama, of the other part, signed in 2003, and the Framework Cooperation Agreement between the European Economic Community and the Republics of Costa Rica, El Salvador, Guatemala, Honduras, Nicaragua and Panama, signed in 1993 ;

**CONSIDERING** the Communication from the Commission to the Council and the European Parliament "Forest Law Enforcement, Governance and Trade (FLEGT) - Proposal for an EU Action Plan", as a first step towards tackling the urgent issue of illegal logging and associated trade;

**AWARE** of the importance of the principles of sustainable forest management set out in the 1992 Rio Declaration on Environment and Development, and, in particular, of Principle 10 concerning the importance of public awareness and participation in environmental issues and of Principle 22 concerning the vital role of indigenous peoples and their communities and other local communities in environmental management and development;

**HAVING REGARD** to the Convention on International Trade in Endangered Species of Wild Flora and Fauna (CITES) and, in particular, the requirement that CITES export permits issued by the Parties to CITES for specimens of species listed in Appendices I, II and III be granted only under certain conditions, in particular that such specimens were not obtained in breach of the relevant laws for the protection of fauna and flora;

**REAFFIRMING** the importance attached by the Parties to the principles and rules which govern multilateral trade, in particular the rights and obligations laid down in the General Agreement on Tariffs and Trade (GATT) 1994 and in other multilateral agreements listed in Annex 1A to the Marrakesh Agreement establishing the World Trade Organisation (WTO) of 1994, and the need to apply them in a transparent and non-discriminatory manner;

**HAVING REGARD** to Council Regulation (EC) No 2173/2005 of 20 December 2005 on the establishment of a FLEGT licensing scheme for imports of timber into the European Community;

**HAVING REGARD** to the Agreement establishing an Association between the European Union and its Member States, on the one hand, and Central America on the other, in particular Article 289 of Title VIII on trade in forest products, whereby the Parties undertake to work together to improve forest-law enforcement and governance and to promote trade in legal timber products and sustainably manage forests through instruments such as Forest Law Enforcement Governance and Trade (FLEGT) Voluntary Partnership Agreements or CITES;

**REAFFIRMING** the commitment and determination of the Parties with respect to the goals of the 2030 Agenda for Sustainable Development, and in particular the contribution that implementing a Voluntary Partnership Agreement (VPA) will make to achieving goal 15 on promoting sustainable forest management, halting deforestation and adopting measures to address the supply of and demand for illegal wildlife products;

**RECOGNISING** the contribution that implementing a FLEGT VPA will make in combating climate change, in line with efforts to reduce greenhouse gas emissions from deforestation and forest degradation (REDD+) by promoting forest-law enforcement and governance;

**RECOGNISING** that the primary objective of the Legality Assurance System of Honduras (LAS) is that all timber and timber products should come within the legal framework; similarly, that the requirements of the LAS be applied without exception to the national market and to exports of timber and timber products from Honduras;

**CONSIDERING** the importance attached by the Parties to the participation of all relevant stakeholders, irrespective of their gender, age, location, religion or beliefs, ethnic origin, race, language, disability or any other condition, including civil society, the private sector, Indigenous and Afro-descendant Peoples of Honduras and the local population, in the success of forest governance policies, in particular through consultations and public information;

**CONSIDERING** that Honduras's forest resources are a strategic asset that is sustainably managed by the *Instituto Nacional de Conservación y Desarrollo Forestal, Áreas Protegidas*

*y Vida Silvestre* (ICF) through a national forestry policy model which is geared to responding effectively to the challenges of sustainable forest management and efficiently performing the tasks of guiding, regulating, managing and facilitating investment in the development of the public and private forestry sector;

**CONSIDERING** that under Honduras's forestry policy and in accordance with its Forestry Law, efforts have been made for the protection and economic development of protected areas, the recovery and sustainable management of coniferous forest, the protection of broadleaved forest and promotion of sustainable forest management, the involvement of community organisations in sustainable forest management, the promotion of national environmental conservation and reforestation, the integrated management of microbasins, the comprehensive monitoring of illegal logging and trade in timber and wildlife, and the institutional modernisation of the forestry, protected areas and wildlife sector;

**CONSIDERING** that this Agreement will constitute a central pillar of the social development programmes which are implemented in the country with the aim of generating employment, improving investment conditions, formulating policy for land-use planning and helping to revitalise industry and ensuring the sustainable use of resources from a social and environmental perspective;

**CONSIDERING** that Forestry Law in Honduras is designed to establish the legal framework for the administration and management of forest resources, protected areas and wildlife, including their protection, restoration, productive use, conservation and promotion, thereby fostering sustainable development appropriate to the country's social, economic, environmental and cultural interests;

**CONSIDERING** that international treaties on the environment and forestry ratified by the National Congress of the Republic of Honduras form part of national legislation, which in turn forms the basis for formulating and implementing the country's forestry policy;

**CONSIDERING** that with the signing of this Agreement, Honduras hopes to strengthen governance, land-use and land-tenure rights and legislation in the forestry sector; establish strong and effective processes for the various stakeholders, thus creating conditions for larger-scale and more transparent investment; establish land-use policies; investment policies which support legal production; and support the implementation of REDD+ policies by directly addressing some of the causes of deforestation and forest degradation;

**CONSIDERING** that the implementation of this Agreement will support efforts to tackle climate change, in accordance with REDD+ efforts;

**TAKING INTO ACCOUNT** that the 1992 Rio Declaration on Environment and Development constitutes a reference text for a global consensus on the management, conservation and ecologically sustainable logging of all types of forests, as well as the recent adoption of the Non-Legally Binding Instrument on all types of forests by the United Nations General Assembly,

HEREBY AGREE AS FOLLOWS:

*Article 1*  
**Objective**

The objective of this Agreement, in accordance with the common commitment of the Parties to sustainably manage all types of forests, is to provide a legal framework to ensure that all imports into the Union of the timber products from Honduras covered by this Agreement have been legally produced and, in so doing, to promote the trade in said timber products.

This Agreement also provides a basis for dialogue and cooperation between the Parties aimed at facilitating and promoting its full implementation and at strengthening the enforcement of forest law and governance.

*Article*  
**Definitions**

For the purposes of this Agreement, the following definitions shall apply:

(a) 'import into the Union' means the release for free circulation into the Union within the meaning of Article 201 of Regulation (EU) No 952/2013 of the European Parliament and of the Council of 9 October 2013 establishing the Union Customs Code, of timber products which cannot be classified as 'goods of a non-commercial nature' as defined in Article 1(21) of Commission Delegated Regulation (EU) No 2446/2015 of 28 July 2015 supplementing Regulation (EU) No 952/2013 of the European Parliament and of the Council as regards detailed rules concerning certain provisions of the Union Customs Code;

(b) 'export' means the physical leaving or taking out of timber products from any part of the territory of Honduras, except for timber products in transit through Honduras;

(c) 'timber products in transit' means any timber products originating from a third country which enter the territory of Honduras under customs control and leave it in the same form without changing their country of origin or being marketed in Honduras;

(d) 'timber products' means the products listed in Annex I;

(e) 'HS code' means a code of up to six digits as set out in the nomenclature of the Harmonised Commodity Description and Coding System established by the International Convention on the Harmonised Commodity Description and Coding System of the World Customs Organisation;

(f) 'FLEGT licence' means a document which confirms that a shipment has been legally sourced and verified in accordance with the criteria laid down in this Agreement.

(g) 'licensing authority' means the authority designated by Honduras to issue and validate FLEGT licences;

(h) 'competent authorities' means the authorities designated by the Member States of the Union to receive, accept and verify FLEGT licences;

(i) 'shipment' means a quantity of timber products covered by a FLEGT licence that is sent from Honduras by a consignor or a shipper and is presented for release for free circulation at a customs office in the Union;

(j) 'legally produced timber' means timber products harvested, produced, processed, transported and marketed by processes that comply with the legislation in force in Honduras, as set out in Annex II, and/or imported and produced in accordance therewith;

(k) 'release for free circulation' means a Union customs procedure which confers the customs status of Union goods on goods which are not from the Union in accordance with Regulation (EEC) No 953/2013, entailing: the collection of any import duties due; the collection, as appropriate, of other charges; the application of commercial policy measures and prohibitions and restrictions; and the completion of other formalities laid down in respect of the importation of goods.

### *Article 3*

#### **FLEGT licensing scheme**

1. A Forest Law Enforcement, Governance and Trade Licensing Scheme ('the FLEGT licensing scheme') is hereby established between the Parties. It establishes a set of procedures and requirements to verify and certify, by means of FLEGT licences, that timber products shipped to the Union have been legally produced. In accordance with Council Regulation (EC) No 2173/2005 and with this Agreement, the Union will not accept shipments from Honduras for import into the Union unless they are covered by FLEGT licences.

2. The FLEGT licensing scheme shall apply to the timber products listed in Annex I.

3. The Parties agree to take all measures necessary to implement the FLEGT licensing scheme.

### *Article 4*

#### **Licensing authority**

1. Honduras shall designate the licensing authority and send its contact details to the European Commission. Both Parties shall make this information available to the public.

2. The licensing authority shall verify that timber products have been legally produced in accordance with the legislation in Annex II. It shall issue FLEGT licences covering shipments of timber products that are legally produced in Honduras and destined for export to the Union. Where appropriate, Honduras shall issue the necessary documentation for timber products in transit through its territory under the control of the Honduran customs authorities.

3. The licensing authority may not issue FLEGT licences for any timber product that is composed of, or includes, timber products imported into Honduras from a third country if the laws of that third country forbid their export, or for which there is evidence that

those timber products were produced in contravention of the laws of the country where the trees were harvested.

4. In accordance with the principle of transparency, the licensing authority shall record and make public its procedures for issuing FLEGT licences. It shall also retain the records of all shipments covered by FLEGT licences and, in accordance with national data-protection legislation, provide these records for the purposes of an independent audit, whilst respecting the confidentiality of exporters' data.

#### *Article 5*

### **Competent authorities of the Union**

1. The European Commission shall inform Honduras of the contact details of the competent authorities designated by the Member States of the Union. Both Parties shall make this information available to the public.

2. The competent authorities shall verify that each shipment is covered by a valid FLEGT licence prior to releasing it for free circulation in the Union. Release for free circulation may be suspended and the shipment held if there is any doubt as to the validity of the FLEGT licence in accordance with Annex III.

3. The competent authorities shall maintain and publish annually a record of FLEGT licences received.

4. In accordance with national legislation on data protection, the competent authorities shall grant the persons or bodies designated by Honduras as independent auditors access to the relevant documents and data.

5. When timber products from species listed in the Appendices to the Convention on International Trade in Endangered Species of Wild Fauna and Flora (CITES) and covered by a FLEGT licence enter the Union, they shall undergo only the examination laid down in Council Regulation (EC) No 338/97 of 9 December 1996 on the protection of species of wild fauna and flora by regulating trade therein. Whatever the case, the FLEGT licence scheme provides assurance of the legal harvesting of these products.

#### *Article 6*

### **FLEGT licences**

1. The licensing authority shall issue FLEGT licences as a means of certifying that timber products have been legally produced.

2. FLEGT licences shall be issued using the form written in Spanish specified in Annex IV.

3. The Parties may, by common agreement, establish electronic systems for the issuing, transmission and receipt of FLEGT licences.

4. The procedure for issuing FLEGT licences and the technical specifications are set out in Annex IV.

*Article 7*

**Definition of legally produced timber**

For the purposes of this Agreement, a definition of legally produced timber is set out in Annex II. This Annex sets out Honduras's national legislation that must be complied with in order for timber products to be covered by a FLEGT licence. It also sets out the principles, criteria, indicators and verifiers serving to prove compliance with the legislation.

*Article 8*

**Verifying the legality of the timber produced or acquired**

1. Honduras shall establish a system for verifying that timber products for shipment have been legally produced and that only shipments verified as such are exported to the Union. The system for verifying legality shall include compliance checks in order to provide an assurance that the timber products for export to the Union have been legally produced or acquired, and that FLEGT licences are not issued for shipments of timber products that have not been legally produced or acquired, or that are of unknown origin. The system shall also include procedures to ensure that timber of illegal or unknown origin does not enter the supply chain.

2. The system for verifying that shipments of timber products have been legally produced is described in Annex V.

*Article 9*

**Release for free circulation of shipments covered by a FLEGT licence**

1. The procedures governing the release for free circulation in the Union of shipments covered by a FLEGT licence are described in Annex III.

2. Where doubts about the validity of any licence arise, the competent authority of the Union Member State taking receipt of the shipment may immediately ask the licensing authority for additional information and/or clarification. If the licensing authority does not reply within 21 calendar days of the date of receipt of the request for additional information, the competent authority shall act in accordance with its applicable national legislation and not accept the licence. If, after provision of additional information, it is established that information on the licence does not correspond to the shipment, the competent authority shall act in accordance with the national legislation in force and not accept the licence. The licensing authority must be informed of each non-acceptance of a FLEGT licence along with the reason for non-acceptance.

3. Where persistent disagreements or difficulties arise in relation to consultations concerning FLEGT licences, the matter may be referred to the Joint Implementation Committee (JIC).

*Article 10*

**Independent auditor**

1. The Parties agree on the need to call on the services of an independent auditor at agreed intervals to check the performance and efficiency of the Legality Assurance System of Honduras (LAS) and of the FLEGT licensing scheme, as set out in Annex VI.
2. Honduras shall engage the services of an independent auditor, in consultation with the Union, to perform the tasks listed in Annex VI.
3. The independent auditor shall submit its observations to the Parties in reports in accordance with the procedure described in Annex VI. Reports of the independent auditor shall be published in accordance with the procedure set out in Annex VI.
4. The Parties shall facilitate the work of the independent auditor, in particular by ensuring that the auditor has access to the information necessary for the performance of its functions on the territory of each Party. However, a Party may, in accordance with its legislation on data protection, withhold any information that it is not permitted to disclose.

*Article 11*  
**Irregularities**

The Parties shall inform each other in accordance with Article 21 if they suspect or have found evidence of any circumvention or irregularity in the FLEGT licensing scheme, particularly, but not exclusively, in relation to:

- (a) fraudulent trade, in particular the diversion of trade from Honduras to the Union via a third country where there is reason to believe that this is done with the intention of avoiding licensing;
- (b) FLEGT licences covering timber products which contain timber from third countries that are suspected of being illegally produced, and;
- (c) fraud in obtaining or using FLEGT licences.

*Article 12*  
**Start-up date for implementation of the FLEGT licensing scheme**

1. The Parties shall notify each other through the JIC when they consider they have made the necessary preparations for the FLEGT licensing scheme to become fully operational.
2. The Parties shall, through the JIC, commission an independent assessment of the FLEGT licensing scheme on the basis of the criteria set out in Annex VII. The assessment shall determine whether the LAS underpinning the FLEGT licensing scheme described in Annex V adequately fulfils its functions.
3. On the basis of the recommendations of the JIC, the Parties shall agree on a date on which the FLEGT licensing scheme will enter into force. They shall notify each other of this date by such written means as the JIC deems appropriate.



### *Article 13*

#### **Application of the FLEGT licensing scheme to timber products not exported to the Union**

1. Honduras shall endeavour to verify the legality of timber products for both domestic consumption and export to markets other than the Union. It shall also make appropriate efforts to verify the legality of the imported timber products using the systems for verifying legality developed for implementation of this Agreement.
2. To support such endeavours, the Union, in dialogue with interested parties, shall encourage use of the systems developed to implement this Agreement for trade in other international markets and with third countries.

### *Article 14*

#### **Schedule for implementation of this Agreement**

1. The Parties, working through the JIC, shall approve a schedule for the implementation of this Agreement.
2. The Parties shall evaluate the progress of implementation with reference to the schedule approved by the JIC.

### *Article 15*

#### **Supplementary and support measures**

1. The areas where there is a need for additional technical and financial resources in order to implement this Agreement and to address the root causes and drivers of illegal logging are indicated in Annex VIII.
2. Honduras shall ensure that capacity-building to implement this Agreement is included in its national planning instruments, poverty reduction strategies and national budget.
3. The Parties shall ensure that activities associated with the implementation of this Agreement are coordinated with relevant existing and future development initiatives, in particular REDD+.
4. The provision of additional resources in accordance with paragraph 1 shall be subject to the normal procedures for programming assistance to Honduras and to the budgetary procedures of Honduras itself.
5. The Parties shall consider the need for a joint arrangement or mechanism whereby the financing and technical contributions of the European Commission and the Member States of the Union are coordinated to support the application of this Agreement.

### *Article 16*

#### **Stakeholder involvement in implementation of this Agreement**

1. Honduras shall involve the stakeholders in the implementation of this Agreement.
2. Honduras shall ensure that the implementation and monitoring of this Agreement involves the relevant stakeholders, irrespective of their gender, age, location, religion or beliefs, ethnic origin, race, language, disability or any other condition, so fostering the

participation of the private sector, civil society, local communities, Indigenous and Afro-descendant Peoples of Honduras and others dependent on forests.

3. The participation in the JIC shall reflect the variety of groups of actors in the Honduran forestry sector: public and private sectors, civil society, Indigenous and Afro-descendant Peoples of Honduras, local communities and others, where necessary.

4. The Union shall hold regular consultations with stakeholders on the implementation of this Agreement, taking into account its obligations under the Convention on Access to Information, Public Participation in Decision-making and Access to Justice in Environmental Matters of 1998.

#### *Article 17*

### **Social safeguards**

1. In order to minimise potential adverse effects on the stakeholders listed in Article 16(2), the Parties hereby agree to assess the impact of this Agreement on their way of life.

2. The Parties shall monitor the impact of this Agreement on the stakeholders listed in Article 16(2), taking reasonable and appropriate steps to mitigate any adverse effects. The Parties may agree on additional measures to address any adverse impact on the basis of a method of evaluating this Agreement which will be agreed by the Parties.

#### *Article 18*

### **Market incentives**

Taking into account its international obligations, the Union shall strive to promote favourable access to its market for the timber products covered by this Agreement. Such efforts shall include:

(a) the encouragement of public and private procurement policies that recognise efforts to ensure a supply of legal timber products; and

(b) a more favourable perception of FLEGT-licensed products on the Union market.

#### *Article 19*

### **Joint Implementation Committee**

1. The Parties shall establish a Joint Implementation Committee (JIC), which shall be responsible for implementing and monitoring this Agreement and managing the independent audit. The JIC shall also facilitate dialogue and exchanges of information between the Parties.

2. The JIC shall be established within three months of the entry into force of this Agreement in accordance with Article 31. Each Party shall nominate its representatives on the JIC, which shall take its decisions by consensus.

3. The JIC shall consider any matter relating to effective implementation of this Agreement. In particular, the JIC shall:

- (a) meet at least twice a year in the first two years, and at least once a year in subsequent years, in a place, at a time and with an agenda previously agreed by the Parties. Additional meetings of the JIC may be called at the request of either of the Parties;
- (b) prepare the agenda for its work and terms of reference for joint action;
- (c) establish its own rules of procedure;
- (d) establish a co-chair arrangement for chairing its meetings;
- (e) draw up, review, update and approve documents and procedures for implementing this Agreement;
- (f) ensure that its work is transparent and that information about its work and decisions is made available to the public;
- (g) if necessary, establish working groups or other subsidiary bodies for areas requiring specific expertise;
- (h) agree on a method for monitoring and evaluating the implementation and impact of this Agreement, and;
- (i) publish an annual report. Details of the contents of this report are set out in Annex X.

4. The specific functions of the JIC are described in Annex X.

#### *Article 20*

### **Transparency and access to public information**

1. In order to improve governance, provision of information to stakeholders must be central to this Agreement. Information shall be published regularly to facilitate the implementation and monitoring of systems, increase transparency, and thus improve stakeholder and consumer confidence, and to ensure that the Parties are accountable. Details of the information to be published are set out in Annex IX.

2. Each Party shall consider the most appropriate mechanisms (media, documents, internet, workshops, annual reports) by which to disseminate the information to the public.

In particular, the Parties shall endeavour to give the various stakeholders associated with the forestry sector reliable, relevant and up-to-date information. These mechanisms are described in Annex IX.

#### *Article 21*

### **Communication on the implementation of this Agreement**

1. The representatives of the Parties responsible for official communications concerning the implementation of this Agreement shall be:

- For the European Union, the Head of the Union Delegation in Honduras
- For Honduras, the Minister-Director of the Instituto Nacional, de Conservación y Desarrollo Forestal, Áreas Protegidas y Vida Silvestre (ICF)

2. The Parties shall communicate the information necessary for implementing this Agreement to each other in a timely manner

*Article 22*

**Confidential information**

1. Each Party undertakes, within the limits of its laws, not to disclose confidential information exchanged under this Agreement. Neither Party shall disclose to the public, nor permit its authorities to disclose, trade secrets or confidential commercial information exchanged under this Agreement.

2. Subject to paragraph 1, the following information shall not be considered confidential:

(a) the number of FLEGT licences issued by Honduras and received by the Union and the volume of timber products exported from Honduras and received by the Union under such licences;

(b) the names and addresses of FLEGT licence-holders and of importers;

(c) the amounts of fees and taxes paid by any exporter, and;

(d) monetary fines imposed or regulatory action taken against any contractor or FLEGT licence-holder.

*Article 23*

**Territorial application**

This Agreement shall apply to those territories in which the Treaty on the Functioning of the European Union is applied under the conditions laid down in that Treaty, on the one hand, and to the territory of Honduras, on the other.

*Article 24*

**Settlement of disputes**

1. The Parties shall seek to settle any dispute concerning the application or interpretation of this Agreement by means of prompt consultations.

2. Consultations under paragraph 1 shall be initiated by means of a written request indicating the matter(s) to be resolved and the date and place of the consultation.

3. If a dispute has not been settled by means of consultations within three months from the date of the initial request for consultations, either Party may refer the dispute to the JIC, which shall endeavour to settle it. The JIC shall be provided with all relevant information for an in-depth examination of the situation with a view to finding an acceptable solution. To this end, the JIC shall be required to examine all possibilities for maintaining the effective implementation of this Agreement.

4. If the JIC is unable to settle the dispute, the Parties may jointly seek the good offices of, or request mediation by, a third party.

5. If it is not possible to settle the dispute in accordance with paragraph 3, either Party may notify the other of the appointment of an arbitrator; the other Party must then appoint a second arbitrator within 30 calendar days of the appointment of the first arbitrator. The Parties shall jointly appoint a third arbitrator within two months of the appointment of the second arbitrator.

6. The arbitrators' decisions shall be taken by majority vote within six months of the third arbitrator being appointed.

7. The decision shall be binding on the Parties and shall be without appeal.

8. The JIC shall establish the working procedures for arbitration.

#### *Article 25* **Suspension**

1. A Party wishing to suspend this Agreement shall notify the other Party in writing of its intention to do so. The matter shall subsequently be discussed by the Parties, taking the opinions of relevant stakeholders into account.

2. Either Party may suspend the implementation of this Agreement if the other Party:

- (a) fails to fulfil its obligations as specified under this Agreement,
- (b) fails to maintain the regulatory and administrative measures and means required to implement this Agreement, or
- (c) acts or fails to act in a way that poses significant risks to the environment, health, safety or security of the people of either the Union or Honduras.

The decision on suspension and the reasons for that decision shall be notified to the other Party in writing.

3. The conditions of this Agreement shall cease to apply 30 working days after notice under paragraph 2 is given.

4. Application of this Agreement shall resume 30 working days after the Party that has suspended its application informs the other Party that the reasons for the suspension no longer apply.

#### *Article 26* **Amendments**

1. A Party wishing to amend this Agreement shall submit the proposal at least three months before the next meeting of the JIC. The Committee shall discuss the proposal and, if a consensus is reached, make a recommendation. Each Party shall consider the recommendation and, if it agrees, approve it in accordance with its own procedures.

2. Any amendment thus approved by both Parties shall enter into force on the first day of the month following the date on which the Parties notify each other of the completion of the procedures necessary for this purpose.

3. The JIC may adopt amendments to the Annexes to this Agreement.

4. Notification of any amendment shall be sent to the joint depositories for this Agreement.

*Article 27*

**Duration**

With effect from its entry into force, this Agreement shall remain valid for five years with tacit extension for an equivalent period, unless it is terminated under the procedure laid down in Article 28.

*Article 28*

**Termination of this Agreement**

Notwithstanding Article 27, either Party may terminate this Agreement by notifying the other Party in writing. This Agreement shall cease to apply 12 months after the date of such notification.

*Article 29*

**Annexes**

The Annexes to this Agreement shall form an integral part thereof.

*Article 30*

**Authentic texts**

This Agreement is drawn up in duplicate in the Bulgarian, Croatian, Czech, Danish, Dutch, English, Estonian, Finnish, French, German, Greek, Hungarian, Italian, Latvian, Lithuanian, Maltese, Polish, Portuguese, Romanian, Slovak, Slovenian, Spanish and Swedish languages, each version being equally authentic. In case of divergence, the Spanish text shall prevail.

*Article 31*

**Entry into Force**

1. This Agreement shall enter into force on the first day of the month following the date on which the Parties notify each other in writing of completion of their respective procedures necessary for this purpose.
2. Notification shall be sent to the General Secretariat of the Council of the European Union and to the Honduran Foreign Ministry, which shall be the joint depositories for this Agreement.

IN WITNESS WHEREOF, the undersigned, Plenipotentiaries, duly empowered to this effect, have signed this Agreement.

DONE at .....

For the European Union

For the Government of the Republic of Honduras

## **ANNEXES**

- I. List of timber products covered by the FLEGT licensing scheme
- II. Honduran legality matrices
- III. Conditions governing the release for free circulation in the Union of timber products exported from Honduras and covered by a FLEGT licence
- IV. Procedure for issuing FLEGT licences
- V. Honduran Legality Assurance System (LAS) for timber products
- VI. Independent audits
- VII. Criteria for evaluating the Honduran Legality Assurance System (LAS) for timber products
- VIII. Supplementary and support measures
- IX. Transparency and access to public information
- X. Joint Implementation Committee

**Annex I**  
**List of timber products covered by the FLEGT licensing scheme**

This Annex contains 19 timber products, including the five obligatory products under Council Regulation (EC) No 2173/2005 of 20 December 2005 on the establishment of a FLEGT licensing scheme for imports of timber into the European Community and 14 additional products selected by Honduras based on a review of data from various sources: the Central Bank of Honduras for the export market, and the ICF (Instituto Nacional de Conservación y Desarrollo Forestal, Áreas Protegidas y Vida Silvestre) register for the domestic market. In 2013, consultations were also held with the various forestry sector operators in the main regions of the country concerning the timber products to be included in this Annex.

Honduran Forestry Law prohibits the export of certain timber products. Article 102 thereof provides that wood from broadleaf species from natural forests may only be exported as processed wood. The export of round or roughly squared wood of these species is therefore not permitted.

Although the export of round or roughly squared wood of these species is prohibited, it is covered by Honduras' Legality Assurance System (LAS) for Timber products (Sistema para Asegurar la Legalidad de los productos de madera de Honduras), at whatever stage of processing <sup>(1)</sup>.

The list in the table below refers to the Harmonised Commodity Description and Coding System established by the International Convention on the Harmonised Commodity Description and Coding System of the World Customs Union, and the Combined Nomenclature of the EU's common customs system.

**Harmonised System (HS) and Combined Nomenclature (CN) codes for timber products covered by the FLEGT licencing scheme**

<b>Number</b>	<b>Code</b>	<b>Description</b>	<b>Usual name in Honduras</b>
1	4401.21	Coniferous wood in chips or particles.	Astillas o chips
2	4401.22	Non-coniferous wood in chips or particles.	Astillas o chips.
3	4401.31	Wood pellets.	Pellets, briquetas.
4	Ex. 4403	Wood in the rough, whether or not stripped of bark or sapwood, or roughly squared; except round or roughly squared wood of broadleaf species from natural forests, corresponding to code 4403 4985.	Madera en rollo, timber.

---

<sup>(1)</sup> In Honduras, wood from broadleaf species is defined as originating from broadleaf trees.



Number	Code	Description	Usual name in Honduras
	Ex. 4403 4985	Wood in the rough, whether or not stripped of bark or sapwood, or roughly squared. Not treated with paint, creosote or other preservatives, Non-coniferous. Of tropical wood from natural forests.  (SA 4403.49.00.00 in Honduras). Export prohibited under Honduran law. In accordance with Article 3 of this Agreement, products under this HS code cannot be covered by a FLEGT licence and therefore cannot be imported into the EU.	
5	4404	Hoopwood; split poles; piles, pickets and stakes of wood, pointed but not sawn lengthwise; wooden sticks, roughly trimmed but not turned, bent or otherwise worked, suitable for the manufacture of walking-sticks, umbrellas, tool handles or the like; chipwood and the like.	Estacas, palos de escoba, palillos, nasas, tampas.
6	4406	Railway or tramway sleepers (cross-ties) of wood.	Durmientes
7	4407	Wood sawn or chipped lengthwise, sliced or peeled, whether or not planed, spliced or end-jointed, of a thickness exceeding 6 mm.	Madera aserrada, madera cepillada, madera en bloque, cuartones.
8	4408	Sheets for veneering (including those obtained by slicing laminated wood), for plywood or for similar laminated wood and other wood, sawn lengthwise, sliced or peeled, whether or not planed, sanded, spliced or end-jointed, of a thickness not exceeding 6 mm.	Chapa, enchapado, plywood.
9	4409	Wood (including strips and friezes for parquet flooring, not assembled) continuously shaped (tongued, grooved, rebated, chamfered, V-jointed, beaded, moulded, rounded or the like) along any of its edges, ends or faces, whether or not planed, sanded or end-jointed.	Molduras, pisos, forros, cielos, machimbres.

<b>Number</b>	<b>Code</b>	<b>Description</b>	<b>Usual name in Honduras</b>
10	4410	Particle board, oriented strand board (OSB) and similar board (for example, waferboard) of wood or other ligneous materials, whether or not agglomerated with resins or other organic binding substances.	Tableros, OSB.
11	4411	Fibreboard of wood or other ligneous materials, whether or not bonded with resins or other organic substances.	Tableros, MDF.
12	4412	Plywood, veneered panels and similar laminated wood.	Contrachapada
13	4415	Packing cases, boxes, crates, drums and similar packings, of wood; cable-drums of wood; pallets, box pallets and other load boards, of wood; pallet collars of wood.	Pallets, tarimas, cajas.
14	4418	Builders' joinery and carpentry of wood, including cellular wood, panels, assembled flooring panels, shingles and shakes.	Puertas, ventanas, marcos, contramarcos, encofrados, postes, vigas.
15	4419	Tableware and kitchenware, of wood	
16	9403.30	Wooden furniture of a kind used in offices	
17	9403.40	Wooden furniture of a kind used in the kitchen	
18	9403.50	Wooden furniture of a kind used in the bedroom	
19	9403.60	Other wooden furniture	

## **Annex II HONDURAN LEGALITY MATRICES**

### **Definition of legal timber and timber products**

***For the purposes of this Agreement, timber and timber products are considered legal when their origin, harvesting, transport, sawing, processing and trade in national and international markets comply with the applicable laws and regulations on forests, the environment, the economy, social affairs, culture, tax and sales, as set out in this Annex and in compliance with Annex V.***

The full and active involvement of governmental institutions, the private sector, civil society organisations, agroforestry groups, communities, academia and the Indigenous and Afro-descendant Peoples of Honduras made it possible to put together the Legality Matrices so that they contained the key information required to improve forestry governance.

The Honduran Legality Matrices are based on 6 Principles, 17 Criteria, 36 Indicators and 56 Means of Verification. They are structured taking into account laws relating to the forestry sector and covering various aspects of public management in terms of:

- Administrative procedures for the recognition of ownership rights of public and private land.
- The correct application of procedures for allocating public forest land to persons or groups.
- Respect for the ancestral rights of the Indigenous and Afro-descendant Peoples of Honduras.
- Respect for the labour rights of forestry sector workers.

In the forest production chain, the aim is to ensure:

- Compliance with the technical and legal requirements for the approval and use of timber product harvesting licences.
- Compliance with the legal provisions for the transport of timber products throughout the supply chain.
- Compliance with the technical and legal provisions for the registration and operation of forest product companies (primary and secondary) and timber yards.
- Compliance with the legal provisions for local, national and international trade.
- Compliance with tariff and tax-related provisions.

The matrices do not include a specific principle relating to the environment because this is seen as a crosscutting issue in all the matrices and implicitly in Principle 3, given that forest operations and harvesting activities are based on forest-management plans whose aim is to ensure proper management and sustainability of the resource. Specifically, the environment comes up in Indicator 3.4.2, which refers to the assessment of the environmental impact in forest management plans, and Indicator 3.6.2, which refers to forestry companies' compliance with environmental mitigation measures.

## 1. Principles

The matrices are arranged according to the following six principles:

- 1: Land ownership rights and land tenure
- 2: Rights of the Indigenous and Afro-descendant Peoples of Honduras living in forest areas
- 3: Compliance with the laws and regulations on forest management and the harvesting, transport and industrialisation of, and trade in, timber products by operators in the forestry sector
- 4: Labour and occupational health and safety obligations
- 5: Rules on international trade in timber products
- 6: Tariff and tax-related obligations

## 2. Considerations for verifying legality

The means of verification for the indicators under each of the six principles in these Legality Matrices consist of administrative documents and records which are produced by public institutions according to demand for services. A verification handbook describes the creation and verification methodologies and the verification frequency for each indicator, plus the physical and electronic archives where the means of verification are stored. The JIC is responsible for this handbook and will review, update and approve it as required.

In order to ensure compliance with the principles, cooperation arrangements will be established between the institutions involved in the forest production chain and the Institute of Forestry Conservation (ICF).

## 3. Sources of timber

The Law on Forestry, Protected Areas and Wildlife (LFAPVS) describes the types of ownership of areas from which timber is cut, processed and sold in Honduras. They are the following:

- A. Public forest areas: These are national forest areas located on land owned by the State, municipal forest areas (*ejido* areas) located on land owned by the municipalities, and forest areas acquired by State institutions, together with all areas owned and leased by the State (Articles 45, 46 and 47 LFAPVS). Leasing means the process by which the owner grants the use and enjoyment of a forest area for a specific period and under certain conditions to a natural or legal person.
  - a. National forest areas consist of:
    - Forest land located within the State's territorial boundaries not owned by anyone else;
    - Forest land acquired by the State or any of its institutions, by means of expropriation, purchase, sale or any legitimate title deed under which it holds rights of ownership, whether or not recorded in the Land Register. These are known as *bienes fiscales* or *bienes nacionales* [State or national property] (Article 46 LFAPVS).
  - b. Municipal (*ejido*) forest areas consist of:

- Forest land covered by title deeds previously granted by the State to the municipalities as '*ejidos*' (communally owned land);
    - Other forest land owned by municipalities under any other title deed, in accordance with the law (Article 47 LFAPVS). Municipal forest areas are public; however, where timber harvesting is concerned, the ICF regards the municipality as a private owner.
  - c. Forest areas acquired by State institutions or *terrenos fiscales* (State-owned land) are State property whose title deeds are held by a public body. Timber harvesting may be carried out in State-owned forests if their management category allows it and if it has been duly authorised by the competent authority in the relevant forest management plan. If this is the case in a State-owned forest (which has been registered in the Catalogue of Inalienable Public Forest Resources (CPPFI) and the Land Register), then it should be considered a private forest rather than a public one.
- B. Private forest areas: These are areas located on land belonging to natural or legal persons governed by private law, full ownership of which is recognised by a legitimate title deed originally issued by the State and recorded in the Land Register (Article 45 LFAPVS).
  - Community or inter-community private forest areas consist of forests located on land owned by rural communities and forest areas owned - or not - by the Indigenous and Afro-descendant Peoples of Honduras. Owing to ancestral rights, forest areas on land traditionally belonging to the Indigenous and Afro-descendant Peoples of Honduras are respected by the State in accordance with national laws and International Labour Organization (ILO) Convention 169 concerning Indigenous and Tribal Peoples in Independent Countries, whether or not they hold the title deed.
- C. Non-forest areas: Currently there is no legal or regulatory framework for the use of timber from these areas, which sometimes supply timber from scattered trees. The supplementary measures in Annex VIII include the structure of such a regulatory framework.

#### **4. Changes to the regulatory, organisational and institutional framework of Honduras**

As all regulatory, administrative and institutional frameworks are subject to change, modifications may need to be made to procedures in Honduras that would lead to adjustments to the content of the indicators described in these Legality Matrices. At least once every two years, these modifications will be analysed and, if necessary, approved by the Joint Implementation Committee (JIC). The JIC will also analyse, at least once every two years, any revisions or updates to this Annex that may be needed to take into account

any relevant changes to the regulatory, administrative and institutional frameworks in Honduras.

## LEGALITY MATRICES

<b>PRINCIPLE 1. FORESTRY SECTOR OPERATORS RESPECT THE PROPERTY RIGHTS AND TENURE OF FOREST AREAS IN ACCORDANCE WITH EXISTING LEGISLATION.</b>		
Criterion 1.1 Public and private operators in the forestry sector involved in forest-based production activities comply with existing legislation for demonstrating ownership of forest areas.		
<i>Indicator 1.1.1 Owners of private forest areas, including community or inter-community and municipal (ejido) forest areas, have documents proving ownership.</i>		
Means of verification:	Legal reference:	Competent institution:
1. Up-to-date full certificate of registered ownership.	Articles 37, 94, 95, Decree No 82-2004, Property Law.	The Institute of Property (IP), Directorate-General for Land Registration and Geography (DGRCG).
<i>Indicator 1.1.2 National forest areas owned by the State are recorded in the IP's Land Register and the ICF's Catalogue of Inalienable Public Forest Resources.</i>		
Means of verification:	Legal reference:	Competent institution:
1. Entry of the title deed in the IP's Land Register. 2. Record of registration of the title deed in the ICF's Catalogue of Inalienable Public Forest Resources (CPPFI).	For means 1: Article 37, Decree No 82-2004, Property Law.  For means 2: Articles 56 and 61, Decree No 98-2007, Law on Forestry, Protected Areas and Wildlife.	For means 1: The IP, Directorate-General for Land Registration and Geography.  For means 2: The ICF, Forestry Resources and Information Centre (CIPF).
Criterion 1.2 Allocation of national and municipal (ejido) forest areas to communities, agroforestry groups and natural or legal persons.		
<i>Indicator 1.2.1 The ICF enters into forest management contracts in national areas to carry out forest management activities in the short, medium and long term.</i>		
Means of verification (either):	Legal reference:	Competent institution:
1. Signed and valid contract for forest management or forestry activities (applies to natural and legal persons).	For both means: Article 77, Decree No 98-2007, Law on Forestry, Protected Areas and Wildlife.	For means 1: The ICF, Department of Forest Management and Development.  For means 2:

2. Signed and valid community forest management contract (applies to agroforestry groups and communities).		The ICF, Department of Community Forest Development.
<i>Indicator 1.2.2 The municipality enters into a community forest management contract in municipal (ejido) areas to carry out forest management activities in the short, medium and long term.</i>		
Means of verification:  1. Signed and valid Community Forest Management Contract for municipal ( <i>ejido</i> ) land.	Legal reference:  Article 128, Decree No 98-2007, Law on Forestry, Protected Areas and Wildlife.  Article 451, Executive Agreement No 031-2010, General Implementing Regulation for the Law on Forestry, Protected Areas and Wildlife.  ICF Agreement No 027-2015 on the forest management of municipal ( <i>ejido</i> ) areas in the community forestry context.	Competent institution:  The municipality, municipal council.  The ICF, Department of Community Forest Development.
<b>PRINCIPLE 2. HONDURAS RESPECTS THE RIGHTS OF THE INDIGENOUS AND AFRO-DESCENDANT PEOPLES OF HONDURAS LIVING IN FOREST AREAS.</b>		
Criterion 2.1 The State of Honduras shall comply with ILO Convention 169 as regards the recognition of rights of ownership and consultation ('free prior and informed consent' - FPIC) for areas owned ancestrally by the Indigenous and Afro-descendant Peoples of Honduras.		
<i>Indicator 2.1.1 The State, through the competent institutions, the IP, INA and ICF, issues full title deeds and the IP records the forest land owned ancestrally by the Indigenous and Afro-descendant Peoples of Honduras to allow commercial timber harvesting.</i>		
Means of verification:  For national and municipal ( <i>ejido</i> ) land (for means 1 and 2):  1. Title deed recorded in the IP's Land Register.	Legal reference:  For means 1, 2 and 3: - Articles 13, 14, 15, 18 and 19, Decree No 26-94 (ratification of ILO Convention 169).  For means 1 and 2:	Competent institution:  For means 1: The IP, Directorate-General for Land Registration and Geography.  For means 2: The INA, National Agrarian Register.



<p>2. Title deed recorded in the INA's National Agrarian Register.</p> <p>For land of the Indigenous and Afro-descendant Peoples of Honduras that is fully owned by the ICF (means 3):</p> <p>3. Title deed, resulting from separation, recorded in the IP's Land Register.</p>	<ul style="list-style-type: none"> <li>- Articles 93, 94, 95, 100, 101 and 125, Decree No 82-2004, Property Law and its implementing regulation.</li> <li>- Article 92, Law on Agrarian Reform amended by the Law on the Modernisation and Development of the Agricultural Sector, Decree No 31-92.</li> </ul> <p>For means 2:</p> <ul style="list-style-type: none"> <li>- Article 69 of the amended Law on Municipalities, Decree No 127-2000.</li> </ul> <p>For means 3:</p> <ul style="list-style-type: none"> <li>- Article 45, Decree No 98-2007, Law on Forestry, Protected Areas and Wildlife.</li> <li>- Decree No 61-2013 of 17 April 2013, authorising the ICF to respond to applications for title deeds for communal and inter-communal areas submitted by organisations of the Indigenous and Afro-descendant Peoples of Honduras.</li> <li>- Agreement No 031-2012 of 3 August 2012, in which the ICF defines the procedure for issuing title deeds for the ancestral lands of the Indigenous and Afro-descendant Peoples of Honduras living in the Río Plátano Biosphere.</li> <li>- As set out in Agreement No 031-2012 of 3 August 2012, a legislative decree is to be published to authorise the separation of the forest areas identified and owned by the ICF, so that the title deeds can be transferred to the</li> </ul>	<p>For means 3: The ICF, Forestry Resources and Information Centre (CIPF).</p>
---	--	--

	Indigenous and Afro-descendant Peoples of Honduras.	
<i>Indicator 2.1.2 The ICF respects the right to free prior and informed consultation in the territories of the Indigenous and Afro-descendant Peoples of Honduras where commercial timber harvesting is intended to take place and by which those Peoples are directly affected.</i>		
Means of verification:  1. Consultation report held by the ICF.  Note: The consultation report held by the ICF sets out the result of the consultation (i.e. the requisite agreement or approval of the measures proposed to carry out commercial timber harvesting) conducted pursuant to ILO Convention 169 concerning Indigenous and Tribal Peoples and the national legislation in force.	Legal reference:  Articles 6 and 15 of Decree No 26-94 (ratification of ILO Convention 169). A reference to the national law on FPIC should be included once the law has been approved.	Competent institution:  The ICF, Department of Community Forest Development.
<b>PRINCIPLE 3. FORESTRY SECTOR OPERATORS COMPLY WITH THE LAWS AND RULES ON FORESTRY MANAGEMENT, HARVESTING, TRANSPORT, PROCESSING OF, AND TRADE IN, TIMBER PRODUCTS.</b>		
Criterion 3.1 Owners and usufructuaries of land with forest management contracts have forest management plans or special plans for agroforestry systems that fulfil the relevant legal requirements.		
<i>Indicator 3.1.1 Owners of private and municipal (ejido) forest areas that carry out harvesting activities have an approved and valid forest management plan.</i>		
Means of verification:  1. Approved and valid forest management plan.	Legal reference:  Articles 70 and 74, Decree No 98-2007, Law on Forestry, Protected Areas and Wildlife.	Competent institution:  The ICF, Department of Forest Management and Development.
<i>Indicator 3.1.2 The usufructuaries (communities, agroforestry organisations and natural or legal persons) of national public forest areas registered with the ICF that carry out harvesting activities have an approved and valid forest management plan.</i>		
Means of verification:  1. Approved and valid Forest Management Plan for national public forest areas.	Legal reference:  Articles 70 and 74, Decree No 98-2007, Law on Forestry, Protected Areas and Wildlife.	Competent institution:  The ICF, Department of Community Forest Development and Department of Forest Management and Development.

<i>Indicator 3.1.3 Owners of areas with privately and municipally owned (ejido) agroforestry systems carry out harvesting activities have a special plan for agroforestry systems that is approved and valid.</i>		
Means of verification:	Legal reference:	Competent institution:
1. Approved and valid special plan for agroforestry systems (PESA).	ICF Agreement No 010-2015, approving the Instructions for the Application of the Technical Standards for Special Agroforestry Systems Plans, on estates of less than 100 hectares.	The relevant ICF Regional Forestry Office.
<i>Indicator 3.1.4 Owners and userfructuaries of forest areas with an approved and valid Forest Management Plan have an Annual Operating Plan, and owners with a special plan for agroforestry systems have an Annual Felling Plan.</i>		
Means of verification:	Legal reference:	Competent institution:
1. Approved Annual Operating Plan (AOP) (for owners of forest areas and userfructuaries of forests that have an <i>approved and valid</i> Forest Management Plan).	For means 1: Article 70(2), Decree No 98-2007, Law on Forestry, Protected Areas and Wildlife, for management plans.	The ICF, Department of Forest Management and Development.
2. Annual Felling Plan (AFP) (for holders of PESAs).	For means 2: ICF Agreement No 010-2015(IV) and (V)(3), instructions for the application of technical standards in PESAs of less than 100 hectares . For PESAs equal to or greater than 100 hectares , the legislation in force will be reviewed and amended (see the relevant supplementary measure in Annex VIII).	
Criterion 3.2 Operators that are in charge of implementing forestry activities and are appointed to carry out these activities under a harvesting licence for Annual Operating Plans, Annual Felling Plans, forest plantations, Rescue Plans and Recovery Plans, are natural or legal persons that fulfil the requirements to operate in the forestry sector.		

<p><i>Indicator 3.2.1 Qualified forestry technicians that are in charge of implementing forestry activities, under harvesting licences for Annual Operating Plans, Annual Felling Plans, forest plantations, Rescue Plans and Recovery Plans, are registered with the ICF and in the records for the corresponding harvesting licences.</i></p>		
<p>Means of verification:</p> <ol style="list-style-type: none"> <li>1. Identification card of the qualified forestry technician.</li> <li>2. Memorandum from the qualified forestry technician agreeing to implement the harvesting licence.</li> </ol>	<p>Legal reference:</p> <p>Article 477, Executive Agreement No 031-2010, General Implementing Regulation for the Law on Forestry, Protected Areas and Wildlife.</p> <p>Article 159, Decree No 98-2007, Law on Forestry, Protected Areas and Wildlife.</p>	<p>Competent institution:</p> <p>The ICF, Department of Forest Management and Development.</p>
<p><i>Indicator 3.2.2 Legal or natural persons that are contracted to implement harvesting activities for Annual Operating Plans, Annual Felling Plans, forest plantations and Rescue Plans and Recovery Plans are registered with the ICF and included in the records for the corresponding harvesting licences.</i></p>		
<p>Means of verification:</p> <ol style="list-style-type: none"> <li>1. Contractor's up-to-date identification card.</li> <li>2. Pre-operational report in the AOPs.</li> </ol>	<p>Legal reference:</p> <p>For means 1: Articles 216 and 217, Executive Agreement No 031-2010, General Implementing Regulation for the Law on Forestry, Protected Areas and Wildlife. Instructions for the application of Agreement No 045 A-2013 on charges for services provided in primary and secondary forest product companies, and timber yards.</p> <p>For means 2: For pine forest AOPs, Chapter 4(c), Administrative Guide to Pine Forest Harvesting Plans, ICF Circular No DE-ICF-001-2013.</p> <p>For all other harvesting licences, there are currently no legal references for means 2, so</p>	<p>Competent institution:</p> <p>For means 1: The ICF, Department of Forest Management and Development.</p> <p>For means 2: The relevant ICF Regional Forestry Office.</p>

	it is included as a supplementary measure as set out in Annex VIII.	
<i>Indicator 3.2.3 Independent forestry technicians are responsible for correctly carrying out forestry activities, under harvesting licences for Annual Felling Plans, forest plantations, Rescue Plans and Recovery Plans. Independent forestry technicians are members of a professional body, solvent and registered in the records for the corresponding harvesting licences.</i>		
Means of verification:  1. Proof of solvency of the independent forestry technician (card or certificate). 2. Memorandum from the independent forestry technician agreeing to implement the harvesting licence.	Legal reference:  For means 1: Article 1, Decree No 73 (issued on 17 May 1962), Law on Compulsory Membership of a Professional Body (Official Gazette No 17692 of 6 June 1962).  For means 2: ICF agreement on the structured order for submitting forest management plans, to be developed as a supplementary measure in Annex VIII.	Competent institution:  The ICF, Department of Forest Management and Development.
<b>Criterion 3.3 The holders and userfructuaries of management plans and timber harvesting licences harvest timber and other non-timber forest products in accordance with legal requirements.</b>		
<i>Indicator 3.3.1 The holders of management plans and other timber harvesting licences meet the technical standards for timber harvesting when carrying out the activities listed in the Annual Operating Plans and other timber harvesting licences.</i>		
Means of verification:  1. Field inspection reports (for pine and broadleaf forests). 2. Record of compliance (or not) with the technical standards at the end of the AOP (only for pine forests).	Legal reference:  For means 1 and 2:  Titles IX and XI of the Administrative Guide to Pine Forest Harvesting Plans.  For means 1: Section 6.17, ICF Agreement No 050-2012 on the technical standards and guidelines for the drafting of forest management plans and operating plans in broadleaf forests.	Competent institution:  The relevant ICF Regional Forestry Office.

<i>Indicator 3.3.2 The owners or userfructuaries of forest areas that carry out harvesting activities have approved and valid rescue plans for forests affected by natural disasters, diseases or infestations, public and/or private construction projects and changes of vegetation on land used for agriculture.</i>		
Means of verification:	Legal reference:	Competent institution:
1. Decision approving the Rescue Plan.	Article 147, Decree No 98-2007, Law on Forestry, Protected Areas and Wildlife.  ICF Agreement No 030/2013, Approval of Rescue Plans.	The relevant ICF Regional Forestry Office and the Department of Forest Management and Development.
<i>Indicator 3.3.3 The owners of forest plantations have an approved and valid plantation certificate and a harvesting licence for harvesting and selling products derived from the management of occupied, forested or reforested private, municipal (ejido) and national areas.</i>		
Means of verification:	Legal reference:	Competent institution:
1. Forest Plantation Certificate.  2. Certified plantation harvesting licence.	Article 149(10) and (11), Decree No 98-2007, Law on Forestry, Protected Areas and Wildlife.  ICF Resolution DE-MP-071-2010, Handbook on Rules for Issuing Forest Plantation Certificates.	For means 1: The ICF, National Reforestation Programme.  For means 2: The relevant ICF Regional Forestry Office.
<b>Criterion 3.4 The holders and userfructuaries of timber harvesting licences apply environmental protection measures that meet the legal requirements.</b>		
<i>Indicator 3.4.1 The owners named on forest management plans for national, municipal (ejido) and private forest areas comply with the protection programme for fires, infestations, forest diseases, water sources, flora and fauna.</i>		
Means of verification:	Legal reference:	Competent institution:
1. Annual protection programme. 2. Technical report on the approved Annual Operating Plans' compliance with the protection programme.	Article 172(3), Executive Agreement No 031-2010, General Implementing Regulation for the Law on Forestry, Protected Areas and Wildlife, Section 6.2, subsections 6.2.1 and 6.2.2, Agreement No 050-2012, Technical Standards for Broadleaf Forests.	The relevant ICF Regional Forestry Office.

	Chapter 1, Paragraph 5, ICF Resolution No DE-MP-285-2010, Guidelines and Standards for Better Forest Management.	
<i>Indicator 3.4.2 The owners named on the forest management plans comply with the Environmental Impact Assessment Programme for Forestry Activities.</i>		
Means of verification:  1. Approved and valid Environmental Impact Assessment Programme for Forestry Activities. 2. Technical compliance reports for the Environmental Impact Assessment Programme contained in the approved Annual Operating Plans.	Legal reference:  For means 1: Article 70, Decree No 98-2007, Law on Forestry, Protected Areas and Wildlife.  Article 170, Executive Agreement No 031-2010, General Implementing Regulation for the Law on Forestry, Protected Areas and Wildlife.  For means 2: ICF Resolution, DE-MP-285-2010, Guidelines and Standards for Better Forest Management, Chapter III, paragraph 3.1.	Competent institution:  The ICF, Department of Forest Management and Development (DMDF).
<b>Criterion 3.5 Timber is transported in accordance with the legislation in force.</b>		
<i>Indicator 3.5.1 Timber transported from the forest to a timber collection centre, primary and secondary forest product companies, and timber yards has a transport permit.</i>		
Means of verification:  1. Transport permit.  N.B.: The ICF authorises three types of transport permit: for roundwood (1), for products and by-products (2) and for sawn timber (3).	Legal reference:  Article 103, Decree No 98-2007, Law on Forestry, Protected Areas and Wildlife. Article 239, Executive Agreement No 031-2010, General Implementing Regulation for the Law on Forestry, Protected Areas and Wildlife.  For broadleaf forests:	Competent institution:  The relevant ICF Regional Forestry Office.

	Legal reference that will apply only to broadleaf forests to be drawn up (see corresponding supplementary measure in Annex VIII).	
<i>Indicator 3.5.2 Authorised invoices are used for the transport, to any destination, of processed timber sold by primary or secondary forest product companies, or timber yards.</i>		
Means of verification:  1. Authorised invoices	Legal reference:  Article 12, Agreement No 189-2014, Implementing Regulation for the Invoicing Scheme and its amendments.  Article 236, Executive Agreement No 031-2010, General Implementing Regulation for the Law on Forestry, Protected Areas and Wildlife.	Competent institution:  The SAR, Invoicing Department.  The relevant ICF Regional Forestry Office.
<i>Indicator 3.5.3 Valid waybills are used when transporting timber to any destination.</i>		
Means of verification:  1. Waybill.	Legal reference:  Articles 11, 19 and 44, Agreement No 189-2014, Implementing Regulation for the Invoicing Scheme and its amendments.	Competent institution:  The SAR, Invoicing Department.
Criterion 3.6 Natural or legal persons that own companies and timber yards comply with the legislation in force when establishing and operating primary and secondary forest product companies and timber yards.		
<i>Indicator 3.6.1 Natural or legal persons that own a primary or secondary forest product company or a timber yard are registered with the municipality and the ICF.</i>		
Means of verification:  1. Business licence. 2. Operating licence.	Legal reference:  For means 1: Article 119, Agreement No 018-93, Implementing Regulation for the Law on Municipalities.  For means 2:	Competent institution:  For means 1: The Municipality, Administration Office or Tax Inspectorate.  For means 2:



	Article 98, Decree No 98-2007, Law on Forestry, Protected Areas and Wildlife.	The ICF, Department of Forest Management and Development.
<i>Indicator 3.6.2 Natural or legal persons that are owners of primary and secondary forest product companies and timber yards comply with the environmental monitoring measures in accordance with environmental impact categorisation.</i>		
Means of verification:  1. Environmental Licence Certificate. 2. Technical monitoring and verification opinion on the environmental monitoring measures contract.	Legal reference:  MiAmbiente: - Article 11(c), Article 83, Decree No. 104-93, General Law on the Environment; - Article 10(3), Article 24(6), Agreement No 008-2015.  Municipalities with licensing powers: - Article 1(28-A), Decree No 181-2007, Amendment to the General Law on the Environment. - Article 19, Agreement No 008-2015, Implementing Regulation for the National Environmental Impact Assessment System.  Municipalities with legal autonomy: Articles 12 and 12a of the Law on Municipalities, Decree No 134-90.	Competent institution:  The Ministry of Energy, Natural Resources, Environment and Mines (MiAmbiente), Directorate-General for Environmental Assessment and Monitoring (DECA).  Municipalities with an agreement on environmental licensing powers, or with legal autonomy.
<b>Criterion 3.7 Operators in the forest production chain comply with the rules in force regarding domestic trade in timber products.</b>		
<i>Indicator 3.7.1. Operators in the forest production chain comply with the rules in these Legality Matrices that apply to the domestic timber products market.</i>		
Means of verification:  1. Monthly report on primary and secondary forest product companies, and timber yards.	Legal reference:  For means 1:	Competent institution:  For means 1, 2 and 3: The ICF, Department of Commerce and Industry (its responsibilities will be handled

<p>2. Record of inputs and outputs. 3. Due diligence dossier.</p>	<p>Articles 225 and 229 of the General Implementing Regulation for the Law on Forestry, Protected Areas and Wildlife.</p> <p>For means 2: Article 219 of the General Implementing Regulation for the Law on Forestry, Protected Areas and Wildlife.</p> <p>For means 3: Specific articles to be drafted once the corresponding legislation has been approved (see corresponding supplementary measure in Annex VIII).</p>	<p>by the Department of Forest Management and Development until it has been created).</p>
<p><b>PRINCIPLE 4. EMPLOYERS IN THE FORESTRY SECTOR COMPLY WITH LABOUR OBLIGATIONS AND OCCUPATIONAL HEALTH AND SAFETY REQUIREMENTS.</b></p>		
<p>Criterion 4.1 Employers in the forestry sector comply with recruitment and wage-related legislation for employees in the forestry sector.</p>		
<p><i>Indicator 4.1.1 Employers in the forestry sector formally recruit their (permanent or temporary) employees.</i></p>		
<p>Means of verification:</p> <p>1. Document or inspection report confirming that employers in the forestry sector comply with the indicator.</p>	<p>Legal reference:</p> <p>Articles 11(e) and 13(1), Decree No 178-2016, of the Labour Inspectorate Law.</p>	<p>Competent institution:</p> <p>The Ministry of Employment and Social Security (STSS), General Labour Inspectorate (DGIT).</p>
<p><i>Indicator 4.1.2 Employers in the forest production chain pay their (permanent or temporary) employees at least the minimum wage.</i></p>		
<p>Means of verification:</p> <p>1. Document or inspection report confirming that employers in the forest supply chain comply with the indicator.</p>	<p>Legal reference:</p> <p>Articles 11(e) and 13(1), Decree No 178-2016, of the Labour Inspectorate Law.</p>	<p>Competent institution:</p> <p>The Ministry of Employment and Social Security (STSS), in the General Labour Inspectorate (DGIT).</p>

	Article 2, Decree 103, of the Minimum Wage Act approved on 3 June 1971 and its amendments. Articles 381 and 387, Decree No 189-1959, Labour Code.	
Criterion 4.2 Employers in the forest production chain observe occupational health and safety rules for employees.		
<i>Indicator 4.2.1 Employers in the forest supply chain ensure the occupational health and safety of their employees at their place of work.</i>		
Means of verification:	Legal reference:	Competent institution:
1. Health and Safety Inspection Report confirming that employers in the forest <i>production</i> chain comply with the indicator.	Articles 391 and 392, Title V, Chapter I, Decree 189-1959, Labour Code.  Article 36, Chapter VII, General Implementing Regulation on Measures to Prevent Workplace Accidents and Occupational Diseases.	The Ministry of Employment and Social Security (STSS), Directorate-General for Social Welfare, Department for Inspection Services and Occupational Health and Safety.
Criterion 4.3 Employers in the forestry sector observe the rules on employees' social welfare.		
<i>Indicator 4.3.1 Employers in the forest production chain register their employees with the Honduran Institute of Social Security (IHSS).</i>		
Means of verification:	Legal reference:	Competent institution:
1. Registration and solvency record. 2. Data extracted from the database, showing a summary of payroll records. 3. Inspection report (when available).	For means 1 and 2: Article 7, Decree No 140-1959, Law on Social Security, and Decree 080-2001 of 1 June 2001, which contains its amendments.  For means 3: Article 96, Decree No 140-1959, Law on Social Security. .	Honduran Institute of Social Security (IHSS), Department for Business Inspections.
<b>PRINCIPLE 5. OPERATORS IN THE FORESTRY SECTOR COMPLY WITH RULES ON INTERNATIONAL TRADE IN TIMBER PRODUCTS.</b>		
Criterion 5.1 Exporters and importers of timber products operate legally with the requisite authorisation and fulfil their tax and customs-related obligations.		
<i>Indicator 5.1.1 Importers and exporters fulfil their customs-related obligations in accordance with the Customs Procedure.</i>		

Means of verification:  1. Data extracted from the Automated Customs Revenue System (SARAH) showing a summary of the customs records for the importer/exporter.	Legal reference:  Article 23, Resolution No 224-2008 (COMIECO-XLIX), Implementing Regulation for the Central American Uniform Customs Code (RECAUCA).	Competent institution:  General Coordination Secretariat of the Government, Customs Revenue Subdirectorate (DARA).
<i>Indicator 5.1.2 Importers fulfil the due diligence requirements applicable to imports of timber products.</i>		
Means of verification:  1. Importer's due diligence dossier.	Legal reference:  Specific articles to be drafted once the corresponding legislation has been approved (see corresponding supplementary measure in Annex VIII).	Competent institution:  The ICF, Department of Commerce and Industry (its responsibilities will be handled by the Department of Forest Management and Development until it has been created).
<i>Indicator 5.1.3 Exporters of timber products derived from species covered by the CITES Convention comply with that Convention.</i>		
Means of verification:  1. CITES certificate.	Legal reference:  Article 116, Decree No 098-2007, Law on Forestry, Protected Areas and Wildlife. SAG Agreement No 936-13, Rules of Procedure for the Implementation of the Convention on International Trade in Endangered Species of Wild Fauna and Flora (CITES).	Competent institution:  SAG, National CITES Office.
<b>PRINCIPLE 6. OPERATORS IN THE FORESTRY SECTOR FULFIL THEIR TARIFF AND TAX-RELATED OBLIGATIONS.</b>		
Criterion 6.1 Operators in the forestry sector are legally established.		
<i>Indicator 6.1.1 Operators in the forestry sector are registered with the Tax Administration.</i>		
Means of verification:  1. The National Tax Register document (RTN).	Legal reference:  Articles 1 and 2, Decree Law No 102-1974, National Tax Register Law.  Article 27, Decree No 51-2003, Fair Taxation Law.	Competent institution:  Revenue Administration Service (SAR), Taxpayer Assistance Department.
Criterion 6.2 Operators in the forestry sector fulfil their tax obligations vis-à-vis the central and municipal Government.		

<i>Indicator 6.2.1 The holders of harvesting licences pay the licensing tax for a Licence to Harvest or Exploit Natural Resources in accordance with the Implementing Regulation for the Law on Municipalities and the fees laid down in the municipal taxation plan in force.</i>		
Means of verification:	Legal reference:	Competent institution:
<ol style="list-style-type: none"> <li>1. Receipt for payment of the tax for the issuing of a Licence to Harvest or Exploit Natural Resources.</li> <li>2. Receipt for payment of the fee for the issuing of a Licence to Harvest or Exploit Natural Resources.</li> </ol>	<p>For means 1: Articles 128 and 130, Agreement No 018-93, General Implementing Regulation for the Law on Municipalities.</p> <p>For means 2: Article 152(c) (15), Agreement No 018-93, General Implementing Regulation for the Law on Municipalities.</p>	The Municipality, Administration Office or Tax Inspectorate.
<i>Indicator 6.2.2 Operators in the forestry sector pay income tax, solidarity contribution and tax on net assets.</i>		
Means of verification:	Legal reference:	Competent institution:
<ol style="list-style-type: none"> <li>1. Tax declarations <ol style="list-style-type: none"> <li>a. CPAT-272 Declaration (Income of Natural Persons) or</li> <li>b. CPAT-352 Declaration (Income of Legal Persons).</li> </ol> </li> </ol>	Article 30, Decree No 25-1963, Law on Income Tax.	The Revenue Administration Service (SAR), Fiscal Intelligence Department.
<i>Indicator 6.2.3 Operators in the forestry sector use the invoicing scheme for sales of timber and sales of services by sawmills.</i>		
Means of verification:	Legal reference:	Competent institution:
<ol style="list-style-type: none"> <li>1. Data extracted from the invoicing module showing a record of the invoices authorised by the SAR.</li> </ol>	Article 10, Agreement No 189-2014, Implementing Regulation for the Invoicing Scheme, other tax documents and tax registration of printers.	The Revenue Administration Service (SAR), Invoicing Department.
<b>Criterion 6.3 Operators in the forestry sector fulfil their tariff-related obligations vis-à-vis the central Government.</b>		
<i>Indicator 6.3.1 Operators in the forestry sector fulfil their tariff obligations.</i>		
Means of verification:	Legal reference:	Competent institution:
<ol style="list-style-type: none"> <li>1. Fiscal Solvency Certificate</li> </ol>		

	Article 49, Decree No 17-2010, Law on Strengthening Revenue, Social Equality and the Nationalisation of Public Expenditure.	The Revenue Administration Service (SAR), Collection and Recovery Department.
--	---	---

## Appendices

### 1. Definition of operators in the forestry sector included in this Agreement documents

In the context of this Agreement, an operator in the forestry sector is any natural or legal person that carries out activities in the forest production chain. Operators in the forestry sector are obliged to comply with the different indicators and means of verification described in this Annex that relate to their involvement in the different stages of the forest production chain.

Operator	Definition/Concept	Indicator/Mean of verification
1. Operators in the forestry sector	Natural or legal persons that carry out activities in the forest production chain. These activities include, among others, forest management, the harvesting, processing, transport, sales, import and export of timber and timber products, as well as changing the use of a forest area. The operators subcontracted to carry out these activities fall under this definition; for example, chainsaw operators, checkers or dispatchers, sales representatives, transporters and consignees of timber products.	Under different headings throughout the table.
2. Rural community	Group of natural persons and their organisations based in a rural location (village or hamlet), in forest areas or places on the edge of these areas, with access to forest management and other agroforestry resources.	1.1.1/1 - 1.2.1/2 - 1.2.2/1 - 2.1.2/1 - 3.1.2/1 - 3.3.2/1
3. Community group	Community organisation with legal personality, including agroforestry organisations, ethnic groups, rural forest companies and organised communities located in a national forest area, whose purpose is to manage, harvest, process and sell goods and services relating to forests.	1.1.1/1 - 1.2.1/2 - 1.2.2/1 - 2.1.1/1 - 2.1.1/2 - 2.1.1/3 - 2.1.2/1 - 3.1.2/1 - 3.3.2/1
4. Forest owner	Natural or legal person that owns property on which there is forest cover, which can be, for example, private, municipal ( <i>ejido</i> ), national, community-owned, or	1.1.1/1 - 1.1.2/1 - 1.1.2/2 - 1.2.1/1 - 1.2.1/2 - 1.2.2/1 - 2.1.1/1 - 2.1.1/2 - 2.1.1/3 - 2.1.2/1 - 3.1.1/1 - 3.1.2/1 - 3.1.3/1 - 3.3.2/1 - 3.3.3/1 - 3.3.3/2

Operator	Definition/Concept	Indicator/Means of verification
	jointly owned by indigenous communities.	
5. Owner of a private forest	Natural or legal person that has full ownership of property on which there is forest cover.	1.1.1/1 - 2.1.1/1 - 2.1.1/2 - 2.1.2/1 - 3.1.1/1 - 3.1.3/1 - 3.3.2/1 - 3.3.3/1 - 3.3.3/2
6. Owner of a municipal ( <i>ejido</i> ) forest	A Municipality that owns property on which there is forest cover.	1.1.1/1 - 1.2.2/1 - 2.1.1/1 - 2.1.1/2 - 2.1.2/1 - 3.1.1/1 - 3.1.3/1 - 3.3.2/1 - 3.3.3/1 - 3.3.3/2
7. Owner named on a forest management plan for a national forest	Natural or legal person that is the beneficiary of an approved forest management plan for a national forest.	2.1.2/1 - 3.1.2/1 - 3.1.4/1 - 3.2.1/1 - 3.2.1/2 - 3.2.2/1 - 3.2.2/2 - 3.2.3/1 - 3.2.3/2 - 3.3.1/1 - 3.3.1/2 - 3.3.2/1 - 3.4.1/1 - 3.4.1/2 - 3.4.2/1 - 3.4.2/2 - 3.5.1/1 - 3.5.2/1 - 3.5.3/1 - 6.2.1/1 - 6.2.1/2
8. Owner named on a forest management plan for a municipal ( <i>ejido</i> ) forest	Natural or legal person that is the beneficiary of an approved forest management plan for a municipal ( <i>ejido</i> ) forest.	2.1.2/1 - 3.1.1/1 - 3.1.4/1 - 3.2.1/1 - 3.2.1/2 - 3.2.2/1 - 3.2.2/2 - 3.2.3/1 - 3.2.3/2 - 3.3.1/1 - 3.3.1/2 - 3.3.2/1 - 3.4.1/1 - 3.4.1/2 - 3.4.2/1 - 3.4.2/2 - 3.5.1/1 - 3.5.2/1 - 3.5.3/1 - 6.2.1/1 - 6.2.1/2
9. Owner named on a forest management plan for a private forest	Natural or legal person that is the beneficiary of an approved forest management plan for a private forest.	2.1.2/1 - 3.1.1/1 - 3.1.4/1 - 3.2.1/1 - 3.2.1/2 - 3.2.2/1 - 3.2.2/2 - 3.2.3/1 - 3.2.3/2 - 3.3.1/1 - 3.3.1/2 - 3.3.2/1 - 3.4.1/1 - 3.4.1/2 - 3.4.2/1 - 3.4.2/2 - 3.5.1/1 - 3.5.2/1 - 3.5.3/1 - 6.2.1/1 - 6.2.1/2
10. Owner of an area with an agroforestry system	Natural or legal person that owns property with a production system that combines agricultural and forest products.	1.1.1/1 - 2.1.1/1 - 2.1.1/2 - 2.1.2/1 - 3.1.3/1 - 3.1.4/2 - 3.2.1/1 - 3.2.1/2 - 3.2.2/1 - 3.2.3/1 - 3.2.3/2 - 3.3.1/1 - 3.3.2/1 - 3.5.1/1 - 3.5.2/1 - 3.5.3/1 - 6.2.1/1 - 6.2.1/2
11. Forest plantation owner	Natural or legal person that is the full or beneficial owner of property with a forest plantation.	1.1.1/1 - 2.1.1/1 - 2.1.1/2 - 2.1.2/1 - 3.2.1/1 - 3.2.1/2 - 3.2.2/1 - 3.2.3/1 - 3.2.3/2 - 3.3.1/1 - 3.3.2/1 - 3.3.3/1 - 3.3.3/2 - 3.5.1/1 - 3.5.2/1 - 3.5.3/1 - 6.2.1/1 - 6.2.1/2
12. User/Occupant	Natural or legal person in possession or occupation of a national or municipal ( <i>ejido</i> ) area without a title deed to the land declaring legal ownership. This operator benefits from legalisation procedures to obtain a usufruct contract allowing it,	1.2.1/1 - 2.1.2/1 - 3.1.2/1 - 3.3.2/1



Operator	Definition/Concept	Indicator/Means of verification
	among other things, to carry out forest management activities.	
13. Forest userfructuary	Natural or legal person who has been appointed by the State forestry administration or municipal government to sustainably manage a public forest (national or municipal/ <i>ejido</i> ) for its benefit.	1.2.1/1 - 2.1.2/1 - 3.1.2/1 - 3.3.2/1
14. Contractor	Natural or legal person that carries out harvesting activities in natural and/or planted pine and broadleaf forests, appointed by the owner named on an approved and valid Forest Management Plan.	3.2.2/1 - 3.2.2/2 - 6.1.1/1 - 6.2.2/1 - 6.2.3/1 - 6.3.1/1
15. Transporter	Natural or legal person in the forestry sector whose activity is the carriage or transport of timber products.	3.5.1/1 - 3.5.2/1 - 3.5.3/1 - 6.1.1/1 - 6.2.2/1 - 6.2.3/1 - 6.3.1/1
16. Qualified forestry technician (TFC)	Forestry or similar professional who ensures the management and sustainable development of forests through management plans or approved operating plans in public or private forests, and who, in accordance with their professional duties, is a certifying officer.	3.2.1/1 - 3.2.1/2 - 6.1.1/1 - 6.2.2/1 - 6.2.3/1 - 6.3.1/1
17. Independent forestry technician (TFI)	Private forestry professional who carries out activities in the forestry sector, excluding the implementation of operating plans.	3.2.3/1 - 3.2.3/2 - 6.1.1/1 - 6.2.2/1 - 6.2.3/1 - 6.3.1/1
18. Exporter	Natural or legal person trading timber products outside the national territory.	5.1.1/1 - 5.1.3/1 - 6.1.1/1 - 6.2.2/1 - 6.2.3/1 - 6.3.1/1
19. Importer	Natural or legal person that purchases timber products from abroad in order to distribute, sell and/or process them inside or outside the country.	5.1.1/1 - 5.1.2/1 - 6.1.1/1 - 6.2.2/1 - 6.2.3/1 - 6.3.1/1
20. Owner of a primary forest product company	Natural or legal person that is the owner or legal representative of a forest product company which carries out the initial processing of roundwood (in its natural state) or any other timber or non-timber raw material from the forest.	3.6.1/1 - 3.6.1/2 - 3.6.2/1 - 3.6.2/2 - 3.7.1/1 - 3.7.1/2 - 3.7.1/3 - 6.1.1/1 - 6.2.2/1 - 6.2.3/1 - 6.3.1/1

Operator	Definition/Concept	Indicator/Means of verification
21. Owner of a secondary forest product company	Natural or legal person that is the owner or legal representative of a forest product company which processes products from a primary forest product company or any other timber or non-timber raw material from the forest.	3.6.1/1 - 3.6.1/2 - 3.6.2/1 - 3.6.2/2 - 3.7.1/1 - 3.7.1/2 - 3.7.1/3 - 6.1.1/1 - 6.2.2/1 - 6.2.3/1 - 6.3.1/1
22. Owner of a timber yard	Natural or legal person that is the owner or legal representative of a piece of land, site or storage area where timber is bought and sold at national level/in the domestic market.	3.6.1/1 - 3.6.1/2 - 3.6.2/1 - 3.6.2/2 - 3.7.1/1 - 3.7.1/2 - 3.7.1/3 - 6.1.1/1 - 6.2.2/1 - 6.2.3/1 - 6.3.1/1
23. Employer	Natural or legal person, under private or public law, that uses the services of one or more employees through an employment contract or a work relationship. This definition applies at all levels.	4.1.1/1 - 4.1.2/1 - 4.2.1/1 - 4.3.1/1 - 4.3.1/2 - 4.3.1/3 - 6.1.1/1 - 6.2.2/1 - 6.2.3/1 - 6.3.1/1

## 2. State institutions linked to the Legality Matrices

Institution concerned	Means of verification
National Institute for Forest Conservation and Development, Protected Areas and Wildlife (ICF)	1.1.2/2 - 1.2.1/1 - 1.2.1/2 - 1.2.2/1 - 2.1.1/3 - 2.1.2/1 - 3.1.1/1 - 3.1.2/1 - 3.1.3/1 - 3.1.4/1 - 3.1.4/2 - 3.2.1/1 - 3.2.1/2 - 3.2.2/1 - 3.2.2/2 - 3.2.3/1 - 3.2.3/2 - 3.3.1/1 - 3.3.1/2 - 3.3.2/1 - 3.3.3/1 - 3.3.3/2 - 3.4.1/1 - 3.4.1/2 - 3.4.2/1 - 3.4.2/2 - 3.5.1/1 - 3.5.2/1 - 3.6.1/2 - 3.7.1/1 - 3.7.1/2 - 3.7.1/3 - 5.1.2/1
Municipalities	1.2.2/1 - 3.6.1/1 - 3.6.2/1 - 3.6.2/2 - 6.2.1/1 - 6.2.1/2
Revenue Administration Service (SAR)	3.5.2/1 - 3.5.3/1 - 6.1.1/1 - 6.2.2/1 - 6.2.3/1 - 6.3.1/1
Institute of Property (IP)	1.1.1/1 - 1.1.2/1 - 2.1.1/1
Ministry of Employment and Social Security (STSS)	4.1.1/1 - 4.1.2/1 - 4.2.1/1
Ministry of Energy, Natural Resources, Environment and Mines (MiAmbiente)	3.6.2/1 - 3.6.2/2
National Agrarian Institute (INA)	2.1.1/2
Ministry of Agriculture and Livestock (SAG)	5.1.3/1
Customs Revenue Subdirectorate (DARA)	5.1.1/1
Honduran Institute of Social Security (IHSS)	4.3.1/1

### 3. List of legal instruments included in the Legality Matrices

The list was drawn up taking account of the order of the legal references cited in the Legality Matrices, starting with Principle I.

1. Decree No 082-2004, Law on Property.
2. Decree No 098-2007, Law on Forestry, Protected Areas and Wildlife.
3. ICF Agreement No 027-2015 on the forest management of municipal (*ejido*) areas in the community forestry context.
4. Decree No 026-94, Ratification of ILO Convention 169.
5. Agreement No 003-2010, Implementing Regulation for the Law on Property.
6. Decree-Law No 170 on Agrarian Reform amended by Decree No 031-92 on the Modernisation and Development of the Agricultural Sector.
7. Decree No 61-2013, authorising the ICF to respond to applications for title deeds for communal and inter-communal areas submitted by organisations of the Indigenous and Afro-descendant Peoples of Honduras.
8. ICF Agreement No 031-2012 on the procedure for issuing title deeds for the ancestral lands of the Indigenous and Afro-descendant Peoples of Honduras living in the Río Plátano Biosphere.
9. ICF Agreement No 010-2015, instructions for the application of technical standards in PESAs (special management plans for agroforestry systems) of less than hectares.
10. Agreement No 031-2010, General Implementing Regulation for the Law on Forestry, Protected Areas and Wildlife.
11. Instructions for the application of Agreement No 045 A-2013 on charges for services provided in primary and secondary forest product companies, and timber yards.
12. ICF Circular No DE-ICF-001-2013, Administrative Guidelines for Harvesting Plans in Pine Forests.
13. Decree No 073, Law on Compulsory Membership of a Professional Body.
14. ICF Agreement No 050-2012 on the technical standards and guidelines for the drafting of forest management plans and operating plans for broadleaf forests.
15. ICF Agreement No 030-2013, Approval of Rescue Plans.
16. ICF Resolution DE-MP-071-2010, Handbook on Rules for Issuing Certificates for Forest Plantations.
17. ICF Resolution No DE-MP-285-2010, Guidelines and Standards for Better Forest Management.
18. Agreement No 189-2014, Implementing Regulation for the Invoicing Scheme and its amendments.
19. Agreement No 018-93, General Implementing Regulation for the Law on Municipalities.
20. Decree No 104-93, General Law on the Environment.

21. Agreement No 008-2015, Implementing Regulation for the National Environmental Impact Assessment System.
22. Decree No 181-2007, Amendments to the General Law on the Environment.
23. Decree No 134-90, Law on Municipalities.
24. Decree No 189-1959, Labour Code.
25. Decree No 178-2016, Labour Inspectorate Law.
26. Decree No 103, Minimum Wage Act approved on 3 June 1971 and its amendments.
27. Agreement No 053-04, General Implementing Regulation on Measures to Prevent Workplace Accidents and Occupational Diseases.
28. Decree No 140-1959, Law on Social Security, and Decree No 080-2001 of 1 June 2001, which contains its amendments.
29. Resolution No 224-2008 (COMIECO-XLIX), Implementing Regulation for the Central American Uniform Customs Code (RECAUCA).
30. SAG Agreement No 936-13, Rules of Procedure for the Implementation of the Convention on International Trade in Endangered Species of Wild Fauna and Flora (CITES).
31. Decree-Law No 102-1974, National Tax Register Law.
32. Decree No 051-2003, Fair Taxation Law.
33. Decree No 25-1963, Law on Income Tax.
34. Decree 017-2010, Law on Strengthening Revenue, Social Equality and Nationalisation of Public Expenditure.

## Annex III

### Conditions governing the release for free circulation in the European Union of timber products exported from Honduras and covered by a FLEGT licence

#### FRAMEWORK

Council Regulation (EC) No 2173/2005 of 20 December 2005 on the establishment of a FLEGT licensing scheme for imports of timber into the European Community <sup>(2)</sup> and its Implementing Regulation <sup>(3)</sup> govern the conditions for entry onto the Union market of timber and timber products from Honduras covered by a FLEGT licence.

These Regulations provide for the adaptation of the procedures laid down therein to national conditions and, in particular, to the possibility that the competent authorities responsible for accepting FLEGT licences on entry into the Union may be the customs authorities or another administrative body. For this reason, the description of the process divides verification into two steps: (1) checks on licence documents and (2) physical checks to ensure conformity of the actual consignment to the licence.

The aim of this procedure is to supplement the checks carried out by Honduras and to verify that the FLEGT licences presented on entry into the Union are indeed those duly issued and registered by the Honduran FLEGT licensing authority and cover the consignments intended by the Honduran authorities. The competent authorities may address their questions with regard to the system for ensuring the legality and validity of Honduran FLEGT licences to the Joint Implementation Committee (JIC) in accordance with Articles 9, 11, 19 and 24 of this Agreement, subject to the information request procedures for competent authorities laid down in Article 3 of this Annex.

#### *Article 1*

#### **Processing of FLEGT licences**

1. The FLEGT licence shall be lodged with the competent authorities of the Member State in which the consignment covered by that FLEGT licence is declared for release for free circulation <sup>(4)</sup>. This may be done electronically or by other expeditious means.

---

<sup>(2)</sup> OJ L 347, 30.12.2005, p.1.

<sup>(3)</sup> Commission Regulation (EC) No 1024/2008 of 17 October 2008 laying down detailed measures for the implementation of Council Regulation (EC) No 2173/2005 on the establishment of a FLEGT licensing scheme for imports of timber into the European Community (OJ L 277, 18.10.2008, p. 23).

<sup>(4)</sup> Release for free circulation is a Union customs procedure. Under Article 201 (2) and (3) of Regulation (EU) No 952/2013 of the European Parliament and of the Council of 9 October 2013 laying down the Union Customs Code, release for free circulation entails: (a) the collection of any import duties due; (b) the collection, as appropriate, of other charges, as provided for under the relevant provisions in force relating to the collection of those charges; (c) the application of commercial policy measures and prohibitions and restrictions insofar as they have not been applied at an earlier stage (in this specific case, the existence of a FLEGT licence shall be verified); and (d) completion of the other formalities laid down in respect of the importation of goods. Release for free circulation shall confer on non-European Union goods the customs status of European Union goods.

2. The competent authorities referred to in Article 1 shall, in accordance with the applicable national procedures, inform the customs authorities as soon as a FLEGT licence has been accepted.

#### *Article 2*

#### **Checks on validity of FLEGT licence documentation**

1. Paper-based FLEGT licences shall conform to the model described in Annex IV Any FLEGT licence that does not meet the requirements and specifications set out in Annex IV shall be invalid.
2. A FLEGT licence shall be considered void if it is lodged on a date later than the expiry date indicated in the licence.
3. Any erasures in or alterations to a FLEGT licence shall not be accepted unless these erasures or alterations have been validated by the licensing authority.
4. The extension of the validity of a FLEGT licence shall not be accepted unless that extension has been validated by the licensing authority.
5. A duplicate or replacement FLEGT licence shall not be accepted unless it has been issued and validated by the licensing authority.

#### *Article 3*

#### **Request for additional information**

1. If there is doubt about the validity or authenticity of a FLEGT licence, a duplicate or a replacement FLEGT licence, the competent authorities may request additional information from the licensing authority.
2. A copy of the FLEGT licence, the duplicate or the replacement FLEGT licence in question may be forwarded together with the request.
3. If necessary, the FLEGT licensing authority shall withdraw the FLEGT licence and issue a corrected copy authenticated by the stamped endorsement 'Duplicate' and forward it to the competent authority.

#### *Article 4*

#### **Verification of the conformity of the FLEGT licence with the consignment**

1. If further verification of the consignment is considered necessary before the competent authorities can decide whether a FLEGT licence can be accepted or not, checks may be carried out to establish whether the consignment in question conforms to the information provided in the FLEGT licence and to the records relating to the relevant licence which are held by the licensing authority.
2. Where the volume or weight of the timber products contained in the

consignment presented for release for free circulation does not deviate by more than 10 % from the volume or weight indicated in the corresponding FLEGT licence, the consignment shall be considered to conform to the information provided in the FLEGT licence as far as volume or weight is concerned.

3. If there is doubt as to whether the consignment conforms to the FLEGT licence, the competent authority may seek further clarification from the licensing authority.
4. The licensing authority may ask the competent authority to send a copy of the FLEGT licence or the replacement FLEGT licence in question.
5. If necessary, the licensing authority shall withdraw the FLEGT licence and issue a corrected copy authenticated by the stamped endorsement 'Duplicate' and forward it to the competent authority.
6. If the competent authority receives no answer within 21 working days of the request for further clarification, as provided for in Article 9 of this Agreement, the competent authority shall reject the FLEGT licence and shall act in accordance with the applicable legislation and procedures.
7. A FLEGT licence shall not be accepted if it has been established, after provision of additional information in accordance with Article 3 of this Annex or further verification in accordance with this Article, that the FLEGT licence does not correspond to the consignment.

#### *Article 5*

### **Verification prior to the arrival of the consignment**

1. A FLEGT licence may be lodged before the arrival of the consignment it covers.
2. A FLEGT licence shall be accepted if it meets all the requirements set out in Annex IV and no further verification in accordance with Articles 2, 3 and 4 of this Annex is deemed necessary.

#### *Article 6*

### **Other matters**

1. Costs incurred while the verification is being completed shall be at the expense of the importer, except where the applicable legislation and procedures of the Member State of the Union concerned determine otherwise.
2. Where persistent disagreements or difficulties arise from verification of FLEGT licences, the matter may be referred to the JIC.

#### *Article 7*



### **Release for free circulation**

1. In box 44 of the Single Administrative Document on which the customs declaration for release for free circulation is made, reference shall be made to the number of the licence that covers the timber products subject to the declaration.
2. Where the customs declaration is made by electronic means, the reference shall be provided in the appropriate box.
3. Timber and timber products shall be released for free circulation only after completion of the procedures described in this Annex.

## **Annex IV**

### **Procedure for issuing FLEGT licences**

#### *Article 1*

#### **General requirements for FLEGT licences**

1. Timber products from Honduras that are listed in Annex I to this Agreement require a FLEGT licence to enter the EU.
2. The 'FLEGT licence' is issued by the *Instituto de Conservación y Desarrollo Forestal, Áreas Protegidas y Vida Silvestre* (ICF) and confirms that the consignment of timber products for export to the European Union has been legally produced and verified in accordance with the criteria and procedures set out in this Agreement.
3. FLEGT licences will be issued in paper or electronic form.
4. A FLEGT licence will be issued for each consignment by each exporter to the first point of entry in the Union.
5. Paper and electronic FLEGT licences will include the information specified in Appendix 1, which must be completed in accordance with the instructions in Appendix 2.
6. Before customs clearance, the applicant will submit to the customs authority the FLEGT licence to export to the Union, or the H-legal licence to export to other destinations, attaching the other required documents. The procedures for issuing the FLEGT licence or the H-legal licence and its relationship with the Single Customs Declaration (DUA) will be developed during the preparation and organisation phase of this Agreement.
7. Once the FLEGT licence expires it will be considered void.
8. Where it is not possible to include all the information specified in format 1 (Appendix 1) for consignments comprising different types of timber products, an authorised annex may be added to the FLEGT licence with the quantitative and qualitative information specified in format 2 (Appendix 1) to this Annex.
9. The authorised annex in accordance with point 8 will include information about the description of the consignment that does not fit in the relevant boxes in format 1.
10. If the qualitative information is given in an Annex (additional pages), the relevant boxes on the FLEGT licence will not give the information on the consignment but will refer to the Annex (additional pages).
11. The requirements and procedures for extending the validity and defining the withdrawal, replacement and management of FLEGT licences will be developed during the preparation and organisation phase of this Agreement. The procedures for issuing FLEGT licences will be made public.

12. The Government of Honduras will provide the Union with an authenticated sample FLEGT licence, examples of the stamps of the licensing authority and signatures of authorised staff.
13. Original, duplicate and replacement FLEGT licences will not be considered valid and will not be accepted if the means of issuing them as established in this Annex are altered or modified.
14. For all approved FLEGT licences, the original and all types of copies will be issued to the exporter in accordance with the relevant provisions of this Agreement.

#### *Article 2*

#### **Responsibility of the FLEGT licensing authority**

1. The licensing authority in Honduras is the ICF via the FLEGT Licensing Unit. The ICF's Legality Verification Unit is responsible for verifying legal compliance.
2. The licensing authority is responsible for the exchange of information between Honduras and the competent authorities of Union Member States, and other Honduran authorities with responsibility for issues associated with FLEGT licences.
3. The licensing authority may extend the period of validity (once only) for up to three (3) months at the request of the exporter. On extending the FLEGT licence the licensing authority will insert and validate the new expiry date.
4. The licensing authority will use a tamper-proof method to ensure the authenticity of FLEGT licences and avoid erasures or alterations.
5. The licensing authority will establish systems to keep paper and electronic records of licences in order to respond to the exporter's application, taking into account its geographical location. The FLEGT licensing scheme will be gradually linked to the Honduras One-Stop Shop System for External Trade (Sistema de Ventanilla Única de Comercio Exterior de Honduras, VUCEH), where conditions allow.
6. In any event, whether the validity of a FLEGT licence is extended or the licence is withdrawn or replaced, the licensing authority will inform the competent authority of the relevant Union Member State.
7. The licensing authority will manage a database for applications received, FLEGT licences issued and applications rejected.

#### *Article 3*

#### **Procedure for issuing FLEGT licences**

1. The procedure to ensure the legality of the products, in accordance with Annex V, will be carried out before issuing the FLEGT licence. The steps for managing FLEGT licences are described below (see Figure 1).
  - (a) To obtain a FLEGT licence, the exporter will present:
    - a FLEGT licence application and
    - an export invoice authorised by the Revenue Administration Service (SAR).

- (b) On receipt of the application, the FLEGT Licensing Unit will:
- i. check with the Legality Verification Unit that the interested party (the exporter) satisfies all the relevant indicators of the legality definition;
  - ii. check that the legality requirement has been satisfied in the supply chain for that consignment:

(c) Based on the information collected on compliance with all applicable indicators of the legality matrices and the supply chain requirements, the Legality Verification Unit will determine whether or not the legality requirements have been met and provide the FLEGT Licensing Unit with the following:

- i. if the operator does not meet the legality requirements, an opinion explaining the reasons why, which will allow the FLEGT Licensing Unit to inform the applicant that the application has been rejected;
- ii. if the operator meets the legality requirements, a 'no-objection' decision, to be used by the FLEGT Licensing Unit.

(d) Based on the application, the supporting documents and the Legality Verification Unit's decision on legal compliance, the FLEGT Licensing Unit will issue or refuse the FLEGT licence.

(e) All information relating to the granting of a FLEGT licence will be entered in a special database.

2. All timber products referred to in Annex I, including samples and demonstration products, are subject to the FLEGT licensing scheme when exported to the Union market.

**Figure 1**  
**Flowchart of the FLEGT licensing procedure**

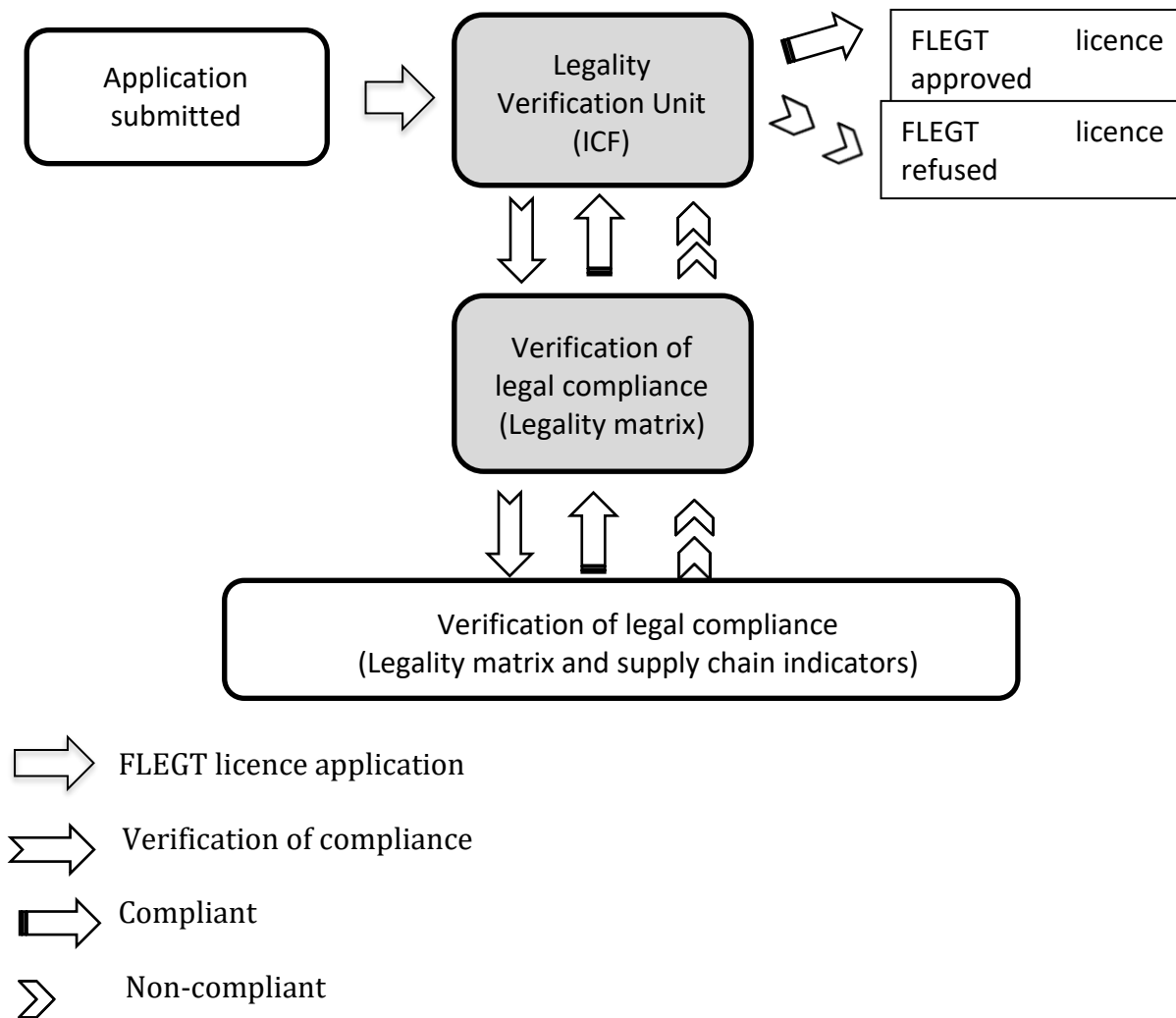

*Article 4*

**Technical specifications for FLEGT licences in paper form**

1. Paper FLEGT licences must comply with the format in Appendix 1 to this Annex.
2. The paper size will be A4. The paper will have watermarks showing various logos, including the Honduran coat of arms or emblem, in addition to the stamp.
3. The FLEGT licences will be completed using a typewriter or computer. They may be completed by hand, if necessary.
4. The FLEGT licensing authority will use a metal stamp, preferably made of steel. However, the FLEGT licensing authority may use an embossing press with combined letters and figures, obtained by means of perforation.
5. The FLEGT licensing authority will use a tamper-proof method to record the quantity entered in figures and letters, in such a way as to make it impossible to insert additional figures or references.

6. The form will contain no erasures or alterations, unless those erasures or alterations have been authenticated with the stamp and signature of the FLEGT licensing authority.
7. The FLEGT licence will be completed and printed in Spanish.

#### *Article 5*

#### **Format for issuing FLEGT licences**

1. FLEGT licences may be issued by the computerised system within Honduras' Legality Assurance System for Timber Products (LAS).
2. For Union Member States which are not linked to the computerised system a paper FLEGT licence will be made available.

#### *Article 6*

#### **Copies of the FLEGT licence**

1. The FLEGT licence will consist of one original document and five copies.
2. The original will be given to the FLEGT licence-holder.
3. The five numbered copies will be used as follows:
  - a) Copy 1: will be retained by the FLEGT licensing authority for future verification purposes;
  - b) Copy 2: will accompany the consignment. It will be given to the FLEGT licence-holder to be sent with the consignment to the purchaser of the product for submission to the customs authority of the Member State in which the consignment covered by the licence arrives for release for free circulation;
  - c) Copy 3: will be given to the FLEGT licence-holder to be sent to the purchaser for submission to the relevant authorities responsible for FLEGT licences of the Member State in which the consignment covered by the licence arrives for release for free circulation;
  - d) Copy 4: is for the Honduran customs authorities for export control purposes.
  - e) Copy 5: is for the records of the FLEGT licence-holder.

#### *Article 7*

#### **Validity, withdrawal and replacement of the FLEGT licence**

##### **1. Validity and extension of the FLEGT licence**

FLEGT licences will be valid on the day of issue and remain valid for six (6) months from the date of issue. The expiry date will be indicated on the FLEGT licence.

##### **2. Withdrawal of the FLEGT licence**

2.1 A FLEGT licence will cease to be valid and should be returned to the licensing authority if the timber products covered by it are lost or destroyed during shipment prior to arrival in the Union.

2.2. A FLEGT licence will be withdrawn in the following circumstances:

- a) For any infringement by the exporter relating to the consignment and identified after the FLEGT licence has been issued;
- b) When no export was carried out and the beneficiary did not request an extension.

2.3 The exporter may also return the licence voluntarily, if it decides not to use it.

### **3. Replacement of the FLEGT licence**

3.1 If the original and/or copies of the licence for the Union competent authorities are lost, stolen or destroyed, the FLEGT licence-holder or its authorised representative may apply to the licensing authority for a replacement on production of proof of the loss, theft or destruction of the original and/or the copies.

3.2 The licensing authority will issue a replacement FLEGT licence on receipt and examination of the licence-holder's request.

3.3. The Government of Honduras will provide the Union with an authenticated sample FLEGT licence, examples of the licensing authority's stamps and the signatures of authorised staff.

3.4 The replacement licence will contain the information and entries appearing on the original FLEGT licence, including the licence number. The replacement FLEGT licence will bear the endorsement 'replacement licence'.

3.5 If the lost or stolen FLEGT licence is found, it must not be used and must be returned to the licensing authority.

#### *Article 8*

### **Management of infringements relating to the issuing of FLEGT licences**

In the event of any infringement or fraudulent information relating to timber products, any falsification, alteration or modification of the information on a FLEGT licence, or a breach of regulations concerning the FLEGT licensing scheme, administrative or legal measures will be taken in accordance with the extent of the infringement and with Honduran legislation.

#### *Article 9*

### **Doubts about the validity and authenticity of a FLEGT licence**

1. If there is doubt about the validity or authenticity of a FLEGT licence, a copy or a replacement licence, the competent Union authority may check in the system or ask the FLEGT licensing authority for additional information. Only the

FLEGT licensing authority will have the responsibility and power to provide information on the validity or authenticity of the licence.

2. If it considers it necessary, the licensing authority may ask the competent authorities of the Union Member State to send it a copy of the FLEGT licence or the replacement document in question.
3. If the FLEGT licensing authority considers it necessary, it will withdraw the licence and issue a corrected copy authenticated by the stamped endorsement 'Duplicate' and forward it to the competent authority of the Union Member State.
4. If the validity of the FLEGT licence is confirmed, the licensing authority will immediately inform the Union competent authority by electronic means. The copies returned will be authenticated in an appropriate manner by the FLEGT licensing authority.
5. If the FLEGT licence in question is not valid, the licensing authority will notify the competent authority of the Union Member State, preferably by electronic means.
6. If there is any doubt about the authenticity and validity of a FLEGT licence, the licensing authority is required to respond to questions from the competent Union authorities and other Honduran authorities, and to provide additional information and clarifications where requested.



**Appendix 1**  
**1. Format of the FLEGT licence**

<b>ORIGINAL</b>	<b>1</b>	<b>1. Licensing authority</b>		<b>2. Importer</b>					
		Name:		Name:					
		Address:		Address:					
		<b>3. FLEGT licence number</b>		<b>4. Date of expiry</b>					
				<table border="1" style="width: 100%; height: 20px;"> <tr> <td style="width: 25%;"></td> <td style="width: 25%;"></td> <td style="width: 25%;"></td> <td style="width: 25%;"></td> </tr> </table>					
	<b>5. Country of export</b>		<b>7. Means of transport</b>						
	<b>6. ISO code</b>								
	<b>8. FLEGT licence-holder (name and address)</b>								
	<b>9. Commercial description of the timber or timber products</b>			<b>10. HS Codes</b>					
<b>1</b>	<b>11. Common and scientific names</b>		<b>12. Country of harvest</b>	<b>13. ISO codes</b>					
	<b>14. Volume (m<sup>3</sup>)</b>	<b>15. Net weight (kg)</b>		<b>16. Number of units</b>					
	<b>17. Distinguishing marks</b>								
	<b>18. Signature and stamp of the FLEGT licence issuing authority</b>								
	Place and date								

## 2. Additional information on consignments

The following information concerns the FLEGT licence.

Item #	Commercial description of timber or timber products	HS code	Common and scientific names	Country of harvest	ISO code of country of harvest	Volume (m <sup>3</sup> )	Weight (kg)	Number of units
1								
2								
3								
4								
5								
6								
7								
8								
9								
10								

<b>Place of issue</b>	<b>Date (day/month/year)</b>	Signature and stamp of the FLEGT licensing authority			
-----------------------	------------------------------	--	--	--	--

## Appendix 2

### Instructions for completing the form

#### General

— Complete in capitals

— The ISO codes for the countries correspond to the international standard two-letter country code.

Box 1	FLEGT licensing authority	Enter the name and address of the FLEGT licensing authority.
Box 2	Importer	Name and Address of Importer.
Box 3	FLEGT licence number	Enter the issuing number.
Box 4	Date of expiry	Period of validity of the FLEGT licence
Box 5	Exporting country	The partner country from where the timber products were exported to the Union.
Box 6	ISO code	Enter the two-letter country code of the partner country indicated in box 5.
Box 7	Means of transport	State the means of transport to the export point.
Box 8	FLEGT licence-holder	Give the name and address of the exporter.
Box 9	Commercial description of the timber or timber products	Enter the commercial description of the timber product(s).
Box 10	HS codes	Give the four- or the six-digit product code established under the <u>Harmonised Commodity Description and Coding System</u> .
Box 11	Common and scientific names	Enter the common and scientific names of the categories of timber used in the product. If more than one category is used in the product, use a separate line for each. This information may be omitted for composite products or components that contain more than one unidentifiable category (e.g. particle boards).
Box 12	Country of harvest	Enter the countries where the categories of timber referred to in box 10 were harvested. If more than one category is used in the product, give all sources of the timber used. This information may be omitted for composite products or components that contain more than one unidentifiable category (e.g. particle boards).
Box 13	ISO codes	Enter the ISO code of the countries referred to in box 12. This information may be omitted for composite products or components that contain more than one unidentifiable category (e.g. particle boards).
Box 14	Volume (m <sup>3</sup> )	State the overall volume in m <sup>3</sup> . This information may be omitted, unless the information referred to in box 15 has been omitted.

Box 15	Net weight (kg)	Give the total weight in kg, namely the net mass of the timber products without immediate containers or any packaging, other than bearers, spacers, stickers, etc. This information may be omitted, unless the information referred to in box 14 has been omitted.
Box 16	Number of units	Indicate the number of units, where a manufactured product is best quantified in this way. This information may be omitted.
Box 17	Distinguishing marks	State any distinguishing marks where appropriate, e.g. batch number, bill of lading number. This information may be omitted.
Box 18	Signature and stamp of the FLEGT licensing authority	The box must be signed by the authorised official and stamped with the official stamp of the FLEGT licensing authority. The place and date must also be stated.

**ANNEX V**  
**HONDURAN LEGALITY ASSURANCE SYSTEM (LAS) FOR TIMBER PRODUCTS**

**Table of contents**

1.	INTRODUCTION.....	64
1.1	General context.....	64
1.2	Objective of the LAS.....	64
1.3	New tools and elements for the improvement of forestry management. ....	64
2.	HONDURAN LEGAL FRAMEWORK APPLICABLE TO THE LAS .....	66
2.1	International conventions and treaties.....	66
2.2	Regional conventions and treaties.....	67
2.3	National legislation on the sustainable management of natural resources.....	67
2.4	National legislation on labour matters.....	67
2.5	National legislation on the payment of state and municipal taxes for the export of timber products.....	67
2.6	National legislation on administrative procedures, transparency mechanisms and public participation.....	67
2.7	National legislation applied by the judicial officers .....	68
3.	ELEMENTS OF THE LAS .....	68
3.1	Definition of legality.....	69
3.2	Verification of compliance with the legality definition.....	69
3.3	Supply-chain controls.....	70
3.4	FLEGT and H-Legal licensing process .....	71
3.5	Independent auditing.....	72
4.	INSTITUTIONAL FRAMEWORK AND ROLE OF ACTORS INVOLVED IN THE IMPLEMENTATION OF THE LAS.....	72
4.1.	Actors involved in implementation of the LAS.....	74
4.2.	State institutions .....	75
4.2.1	National Institute for Forest Conservation and Development, Protected Areas and Wildlife (ICF).....	75
4.2.2	Revenue Administration Service (SAR).....	75
4.2.3	Municipalities .....	76
4.2.4	Institute of Property (IP).....	76
4.2.5	Ministry of Employment and Social Security (STSS).....	76
4.2.6	Honduran Institute of Social Security (IHSS) .....	76
4.2.7	Ministry of Energy, Natural Resources, Environment and Mines (MiAmbiente)	76

4.2.8	National Agrarian Institute (INA) .....	76
4.2.9	Ministry of Agriculture and Livestock (SAG).....	77
4.2.10	Customs Revenue Subdirectorate (DARA).....	77
4.2.11	Government institutions indirectly involved .....	77
4.3.	Private Forestry Sector .....	80
4.4.	Civil society organisations.....	81
4.4.1	Local organisations.....	81
4.4.2	Non-Governmental Development Organisations.....	81
4.5.	Indigenous and Afro- descendant peoples of Honduras .....	82
4.6.	Capacity-building.....	82
5.	COVERAGE/SCOPE OF THE LAS.....	82
5.1	Timber products included in the LAS.....	83
5.2	Markets covered by the LAS .....	83
5.3	Sources of timber covered by the LAS .....	83
5.3.1	Timber harvested in Honduras.....	84
5.3.2	Imported wood.....	85
5.3.3	Timber not covered by this Agreement.....	85
5.4	Scope of operators included in the LAS.....	85
6.	VERIFICATION OF COMPLIANCE WITH THE LEGALITY DEFINITION .....	90
6.1	Legality verification principles.....	90
6.1.1	Institutions involved in legality verification .....	90
6.1.2	Verification procedures based on the legality matrices .....	92
6.1.3	Storage of the means of verifying legality .....	93
6.1.4	Information systems and verification functionalities .....	93
6.1.5	Risk management principle .....	96
6.1.6	Legality audit resulting in a legal compliance certificate.....	98
6.2	Obligation of operators with regard to legality verification .....	99
7.	VERIFICATION OF THE TIMBER AND TIMBER PRODUCT SUPPLY CHAIN .....	100
7.1	Principles of supply-chain verification.....	101
7.2	Identification of timber products .....	102
7.3	Declaration of supply chain information by operators .....	103
7.4	Verification of imported timber products .....	103
7.5	Verification of timber products in transit .....	103
7.6	Verification of confiscated timber products.....	104
7.7	Verification of timber products sourced from land subject to a change in use .....	104

8.	RECOGNITION OF PRIVATE CERTIFICATION .....	105
9.	HANDLING OF CASES OF NON-COMPLIANCE WITH THE LAS .....	108
10.	MECHANISMS FOR HANDLING COMPLAINTS .....	109
10.1	Introduction .....	109
10.2	Objectives.....	109
10.3	Types of complaint-handling mechanism .....	110
10.4	Establishment of the complaint-handling mechanisms and governing principles .....	111
11.	CONSULTATION, PARTICIPATION AND COORDINATION MECHANISMS CONCERNING THE IMPLEMENTATION OF THE LAS.....	113
11.1	Joint Implementation Committee .....	113
11.2	Technical Committee .....	114
11.3	Interinstitutional Secretariat for the Implementation of the FLEGT-VPA.....	114
11.4	National Strategy against Illegal Logging and its links to the FLEGT-VPA.....	115
12.	INCENTIVE, PROMOTIONAL, SAFEGUARD AND MITIGATION MEASURES DESIGNED TO INVOLVE THE SECTOR'S VARIOUS ACTORS IN THE IMPLEMENTATION OF THE LAS.....	116
	Appendix 1. Links in the supply chain (pine forest) .....	117
	Appendix 2. Links in the supply chain (broadleaved forest).....	133

## **1. INTRODUCTION**

### **1.1 General context**

Latin America has the highest rate of deforestation in the world and Honduras has one of the region's highest annual deforestation rates. Deforestation and forest degradation have a range of causes, mainly the encroachment of extensive cattle farming and monocultures (such as oil palm), illegal logging in the form of clearance, forest fires and unsustainable harvesting.

The repercussions and negative impacts as illustrated by the destruction and deterioration of forests caused by illegal logging, and the conversion of rainforest into farmland, results in reduced biodiversity and the limitation or loss of the natural resilience of forest ecosystems. There is also the financial loss resulting from non-payment of fees and tax evasion.

### **1.2 Objective of the Legality Assurance System of Honduras for Timber Products (LAS)**

The objective of the LAS is to improve governance in the country's forestry sector, ensuring strict legal compliance by all operators in the forest supply chain.

This objective covers the assignment of forest-use rights, the harvesting of raw materials, transportation of timber, primary processing, secondary processing and trade in timber products on both domestic and international markets, based on the application and enforcement of current legislation and the improvement of existing government control systems.

### **1.3 New tools and elements for the improvement of forestry management.**

Although the licensing of legal timber under FLEGT is a key objective of the process of negotiation and implementation of the VPA, it is not the only expected outcome. For these licences to be issued, and to meet the expectations of Honduras and the EU in terms of improving forest governance and promoting the legal timber trade, new tools need to be developed to reinforce legality verification. For this reason, the Agreement proposes a number of new and innovative elements that are expected to have a positive impact on governance of the forestry sector. This set of elements, in place or yet to be developed, make up the Honduran Legality Assurance System for Timber Products. These elements, at both organisational and institutional levels, include in particular:

#### **Definition of legal timber**

- a. Establishing legal requirements, which are included in the legality matrices, for all sources of timber supplying the domestic market, and exports to any destination, including imported wood.



## Supply chain controls

- b. **Implementation milestone of this Agreement:** Development and implementation of the Timber Traceability IT System (SIRMA): improved checking and controls on the volumes of wood along the supply chain, thanks to connection with other information systems (both the internal ICF system and systems in place at other institutions) and to information exchange with other countries (medium term).
- c. Information exchange and cross-referencing between SIRMA and Honduras's Automated Customs Revenue System (SARAH) (medium term).
- d. **Implementation milestone of this Agreement:** Introduction of due diligence for all operators. Inclusion in the legal framework of an obligation that reduces the risk of operator non-compliance to a minimum, regardless of whether the product is sourced locally or overseas (medium term).

## Verification procedures

- e. Tougher application of all legislation included in the legality matrices (long term).
- f. Reinforcement of controls on harvesting in forest areas subject to rescue and recovery plans, particularly where greater efforts are required for monitoring along the supply chain (long term).
- g. Consolidation of the National Forestry Information System (SNIF) to create an effective and appropriate link to other related institutions, and also to allow users to access information that is of interest to them (medium term).
- h. **Implementation milestone of this Agreement:** Creation and management of a database on the degree of operator non-compliance with LAS requirements (medium term).
- i. **Implementation milestone of this Agreement:** Implementation of a risk-based legality audit as a means of checking that all operators comply with LAS indicators and requirements (medium term).
- j. **Implementation milestone of this Agreement:** Creation of a legal compliance certificate — resulting from the legality audit — as proof of compliance with LAS requirements (medium term).
- k. Recognition of private voluntary certification, subject to equivalence in the legality matrices. Bearing in mind the procedures set out in Section 8 of this Annex, the legality, forest management and/or chain of custody certificates issued by accredited certifying bodies may be accepted as evidence of partial or full compliance with the legality indicators in order to avoid duplication of work and as a way to simplify this verification (medium term).

## FLEGT Licensing Procedures

- l. Issue of FLEGT licences, ensuring compliance with LAS requirements for all shipments of wood to the EU. The requirements for the issue of H-Legal licences must also be complied with for wood exported to other countries (medium term).

## **Independent audit**

- m. Independent audit of the system, to ensure the credibility of all elements of the LAS and propose adjustments to remedy any weaknesses identified (medium term).
- n. **Implementation milestone of this Agreement:** Creation of an Interinstitutional Secretariat for the Implementation of the FLEGT-VPA (SIIAVA) to coordinate the activities and input of the various government institutions involved in the development and implementation of the LAS. This body will be a space for dialogue and coordination to ensure, together with other bodies such as the Technical Committee, successful implementation of this Agreement in an interactive and deliberative manner, so that all stakeholders are involved, aware of and committed to improving forest governance (short term).
- o. **Implementation milestone of this Agreement:** Implementation of Free, Prior and Informed Consultation (FPIC) in the forestry sector, under the provisions of the corresponding law once in force (medium term).
- p. Stepping up of efforts to place forest land without title deeds in state hands, with a focus on the legalisation ("regularización" and "saneamiento jurídico") of land not owned by the State and covered under the community forest management contracts issued by the ICF (long term).
- q. Stepping up of efforts to legalise ownership of ancestral lands by the Indigenous and Afro-descendant Peoples of Honduras (long term).
- r. Reinforcement of the institutional capacity of the Ministry of Employment and Social Security (STSS) and the Honduran Institute of Social Security (IHSS), providing them with the necessary resources for the effective facilitation and supervision of the indicators and means of verification of the legality matrices (long term).
- s. Capacity-building for artisan operators in the sector, in terms of legal compliance (long term).

## **2. HONDURAN LEGAL FRAMEWORK APPLICABLE TO THE LAS**

The legal framework for timber products in Honduras has diverse elements, consisting of international conventions and treaties (regional and extra-regional), the Constitution of the Republic, secondary laws, regulations and other standards, applied by particular government institutions depending on their sphere of competence. The institutions involved in the LAS liaise with each other to verify the legality of Honduras's timber products.

The legality matrices set out in Annex II and below describe the key legal instruments relating to the different elements of legality and the LAS, which will be compared before each FLEGT licence is issued.

### **2.1 International conventions and treaties**

- International Labour Organization Convention 169 concerning Indigenous and Tribal Peoples in Independent Countries.

- Convention on International Trade in Endangered Species of Wild Fauna and Flora.
- United Nations Conference on Environment and Development.
- United Nations Framework Convention on Climate Change, and in particular the 2015 Paris Agreement, which has become the main international instrument for dealing with climate change.

## **2.2 Regional conventions and treaties**

- Convention for the Conservation of the Biodiversity and the Protection of Wilderness Areas in Central America. The purpose of this convention is to conserve as much as possible land and marine biological diversity in the Central American region. It was signed in Managua, Nicaragua in 1992, by the presidents of the Republics of Costa Rica, El Salvador, Guatemala, Honduras, Nicaragua and Panama.
- Central American Alliance for Sustainable Development. This is a regional strategy for the coordination and consultation of interests, development initiatives, responsibilities and harmonisation of rights, signed in 1994 by the presidents and representatives of the Republics of Belize, Costa Rica, El Salvador, Guatemala, Honduras, Nicaragua and Panama.
- Regional Convention for the Management and Conservation of Natural Forest Ecosystems and for the Development of Forest Plantations. The purpose of this convention is to promote national and regional mechanisms to avoid changes in use of areas with forest cover located on land with forestry potential and to recover areas of deforestation. It was signed in Guatemala City, Guatemala, in 1993 by the foreign ministers of the Republics of Costa Rica, El Salvador, Guatemala, Honduras, Nicaragua and Panama.

## **2.3 National legislation on the sustainable management of natural resources**

- Decree No 131-1982, Constitution of the Republic of Honduras.
- Decree No 181-2009, General law on waters.

## **2.4 National legislation on labour matters**

- Agreement No 101-JD-71, Implementing regulation for the law on social security.

## **2.5 National legislation on the payment of state and municipal taxes for the export of timber products**

- Decree No 170-2016, Tax code.
- Decree No 194-2002, Law on financial equilibrium and social protection.
- Resolution No 223-2008 on the Central American Uniform Customs Code (CAUCA).
- Ministry of Finance Agreement No 0630, Implementing regulation for the law on foreign exchange revenue from exports.

## **2.6 National legislation on administrative procedures, transparency mechanisms and public participation**

- Decree No 170-2006, Law on transparency and access to public information.
- Decree No 152-1987, Law on administrative procedures and its implementing regulation.

## **2.7 National legislation applied by the judicial officers**

- Decree No. 144-1983, Penal code of Honduras.

## **3. ELEMENTS OF THE LAS**

The LAS comprises the following:

- 1) *A definition of legal timber* that clearly establishes the aspects of the law for which the Honduran Legality Assurance System for Timber Products will systematically seek proof of compliance, regardless of the intended market for the products.
- 2) *Supply chain controls* to track timber from forest operations or the point of import to the last link in the supply chain.
- 3) *Verification procedures* to ensure and document compliance with all elements of the legality definition and supply-chain controls;
- 4) *Procedures for the issuing of FLEGT licences for timber products destined for the Union.*
- 5) *Independent audits* to ensure that the system is as effective and efficient as it should be, as agreed by the Parties.

### **3.1 Definition of legality**

The legality of timber under this Agreement is defined in Annex II. This Annex is closely linked to the other Annexes as part of the Honduran Legality Assurance System for Timber Products (LAS). It includes a definition of the legal requirements applied under the Voluntary Partnership Agreement that are linked to the challenges to forest governance identified by the actors in the sector in a national dialogue.

The detailed definition of legality in the legality matrices provides the basis for checking the various supply-chain operators' compliance with the indicators, means of verification and traceability requirements and the respective monitoring and control by the relevant institutions. Independent audits ensure that the system is as effective and efficient as it should be.

### **3.2 Verification of compliance with the legality definition**

Legality verification:

- - ensures that timber products are legal. This means checking that all the indicators included in the legality matrices have been met by the operators in their sphere of competence in the forestry sector.
- - ensures processing of cases of non-compliance and the application of corrective or preventive measures.
- - requires unequivocal proof that timber products and related activities meet the requirements established in the definition of legality.
- - shows compliance through physical and documentary checks and through checks of systematically collected information and data verified at various points along the supply chain.
- - documents procedures and files evidence to allow the licensing authority to assess the legality of a shipment prior to issuing a FLEGT or H-Legal licence.
- - clearly defines and documents the roles and responsibilities of all institutions involved in the verification process.

The State of Honduras, by means of its specialist institutions and a verification manual approved by the Joint Implementation Committee (JIC), will have methodologies and means in place to check compliance with legal requirements by the sector's various actors and operators. These methodologies and means of verification are introduced in Section 6.1 of this Annex.

The system provides for the detection of any failings and instances of non-compliance, the imposing of penalties where applicable, the proposal of necessary corrective measures where appropriate, and assurance that measures to correct these failings will be taken.

The institutions involved in the LAS have IT tools and protocols to verify compliance with the indicators in the legality matrices, which are described in more detail in Section 4 of this Annex.

Legality verification includes action on the ground such as supervisory inspections and technical auditing, plus routine inspections to verify compliance with technical and administrative standards, performed by the relevant authorities depending on the type of indicator in question.

Inspections at roadsides and checkpoints are also conducted with the support of the judicial officers<sup>5</sup> and the collaboration of the law enforcement authorities (Honduran armed forces, the national preventive police, MP, PGR) to check compliance with the law in the transportation of timber products, at all times reporting to the competent authorities in order for the necessary measures to be taken.

Civil society organisations (i.e. Forestry Advisory Councils)<sup>6</sup> jointly perform social oversight to ensure compliance with the technical and administrative rules governing the execution of management plans, operating plans and other harvesting licences. The Forest Advisory Councils may report their findings and recommendations to the SIIAVA, to the FLEGT-VPA Joint Implementation Committee or its technical branches, to this Agreement's independent auditing department, and to the general public.

The frequency of verification will be established using a risk-based approach, taking into account the competencies and responsibilities of the public institutions involved in the supply chain and administrative records (fines, complaints and others) suggesting a risk of illegality. These risks have been taken into consideration for the forestry operators as well as for the service providers themselves. The frequency of verification by the various public institutions will be described in the legality verification manual, introduced in Section 6.1 of this Annex.

The institutions responsible for verification of legality will hold files of means of verification that contain both digital documents and hard copies (images of documents, geographical information, etc.). These files will contain a chronological sequence of documented facts. For security purposes, government institutions will hold a digital copy of these files as backup. All these files, in accordance with Annex X on Public Information and Transparency, are public files insofar as the law on transparency and access to public information considers them to be public information.

Checking of legal compliance is a key stage in the exportation of timber products, include the issuing of FLEGT and H-Legal licences, as it provides proof of compliance.

### **3.3 Supply-chain controls**

---

<sup>5</sup> Judicial officers are those civil servants of the State who intervene in the judicial system and who carry out essential functions for the respect and guarantee of citizens' rights. According to Article 314 of the Constitution, jurisdictional bodies are responsible for applying the law in individual cases, for judging and executing judgement; where necessary, they may require the support of the law enforcement authorities.

<sup>6</sup> The advisory councils on forestry, protected areas and wildlife are public participation bodies that advise and support the ICF and operate at national, regional, municipal and community level (Articles 21 to 28 of the Forestry Law).

Traceability of timber is one of the requirements of the LAS, in accordance with the Honduran legal framework. The ICF has supply-chain monitoring tools such as the SNIF and the SIRMA, among others. Both systems are already in operation, but new modules are planned, in line with the requirements established under this Agreement. They are therefore considered to be under construction, and the development of some functions is included in the supplementary measures in Annex VIII.

The starting point for monitoring the supply chain is the harvesting licence for timber felled in Honduras, and the Single Customs Declaration for timber imported into Honduras.

Harvesting licences, transport permits and waybills, production reports, input and output and delivery reports for SAR-authorized invoices, as well as Single Customs Declarations, are the key documents for monitoring timber product flow under the LAS. These documents will be recorded in the SNIF and the SIRMA, once these systems have been fully developed, making it possible to calculate the volume of timber circulating in each stage of the supply chain, as described in Section 7.1.

The authorities employ two means of data verification: validation and reconciliation. Validation consists of comparing and contrasting the operator-generated data with the data collected by government representatives, as shown in column 3.1 of Appendices 1 and 2 to this Annex.

Data reconciliation consists of comparing and analysing the data reported between one stage of the supply chain and the next in order to detect differences indicating the presence of unchecked or illegal timber. Data reconciliation is presented in column 3.2 of Appendices 1 and 2 to this Annex.

Proper supervision and the application of clearly defined procedures for validation and reconciliation at each stage of the supply chain play a decisive role in ensuring that the timber moving from one point to another is legal, thereby avoiding contamination of legally circulating timber by that from unchecked or illegal sources.

### **3.4 FLEGT and H-Legal licensing process**

The issuing of FLEGT and H-Legal licences takes place after positive and conclusive verification of compliance with all the requirements concerning the definition of legality and monitoring of the supply chain for timber products.

The FLEGT licence is the final compulsory requirement for timber products included on the list of products agreed between the parties, as set forth in Annex I to this Agreement, to be exported from Honduras to any country in the Union. For exports to countries outside the Union, the same legality verification is performed. The difference is that an H-Legal licence is required, rather than a FLEGT licence.

Annex IV describes the procedure for issuing FLEGT licences. The exporter submits the FLEGT licence for customs clearance when exporting to the Union, and the H-Legal licence when exporting to non-Union markets, together with the other documentation required by the Customs Authority.

### **3.5 Independent auditing**

Independent auditing is an indispensable element of the LAS as it maintains the credibility of the system. The independent audit checks that the mechanisms implemented within the LAS to demonstrate the legality of all stages of the supply chain in timber products (including logging, transport, primary processing, secondary processing and trade) are functioning, and that they fully meet all supply-chain requirements and the provisions laid down by the FLEGT and H-Legal licensing authority.

The independent audit is part of the LAS and must be performed prior to commencing FLEGT licensing. Auditing procedures and their implementation will be defined in more detail during the preparatory and organisational phase of this Agreement.

The scope and principles of audits are defined in the terms of reference for independent audits in Annex VI.

## **4. INSTITUTIONAL FRAMEWORK AND ROLE OF ACTORS INVOLVED IN THE IMPLEMENTATION OF THE LAS**

This section describes the role of the different actors involved in the implementation of the LAS. It describes how, according to their respective responsibilities, they support or implement in practice the requirements of this Agreement, or perform the necessary verification to ensure compliance with these requirements, and how they liaise with and complement each other to ensure the legality of timber products.

For the preparatory and organisational phase of this Agreement, institutions, private-sector operators and civil society, including agroforestry organisations and representatives of the Indigenous and Afro-descendant Peoples of Honduras, must perform a critical review of their capacity in the light of their responsibilities for legality verification and compliance. Annex VIII deals with all aspects of strengthening the technical and institutional capacities mentioned in this section.

The knowledge and appropriate management of the entire process required to implement the LAS, the institutional targets for participation and good practice, the responsibility of each actor involved and proper interinstitutional coordination all require a high level of training and capacity-building. For this reason, supplementary measures were included in Annex VIII to build the capacity of the actors involved in this Agreement.

Section 11 of this Annex sets out the coordination bodies, such as the Interinstitutional Secretariat for the Implementation of the FLEGT-VPA, that will be created or maintained to implement the LAS. In order to reaffirm the institutional agreements on the implementation of the this Agreement, one or more memoranda of understanding will be



concluded between public sector institutions, involving at least: The National Institute for Forest Conservation and Development, Protected Areas and Wildlife (ICF); the Revenue Administration Service (SAR); the Association of Honduran Municipalities (AMHON); the Institute of Property (IP); the National Agrarian Institute (INA); the Secretariat of State in the Ministry of Employment and Social Security (STSS); the Honduran Institute of Social Security (IHSS); the Secretariat of State in the Ministry of Energy, Natural Resources, Environment and Mines (MiAmbiente); the Secretariat of State in the Ministry of Agriculture and Livestock (SAG); the Customs Revenue Subdirectorate (DARA); the national preventive police, reporting to the Secretariat of State in the Ministry for Security (SSN); the Public Prosecutor's Office (MP); the Attorney-General's Office (PGR); the Supreme Court of Justice (CSJ); the Honduran armed forces, reporting to the Secretariat of State in the Ministry of National Defence (SEDENA); the National Directorate of Indigenous and Afro-Honduran Peoples (DINAFROH); the Institute for Access to Public Information (IAIP); and the National Commission on Human Rights (CONADEH).

Cooperation agreements will also be established to ensure appropriate coordination between these institutions, based on and following the example of current agreements such as the Interinstitutional Agreement for the Legalisation and Ownership of Land, signed by the INA, IP and ICF in October 2015.

Considering that lack of defined ownership is one of the underlying causes of the widespread weak governance found in the forestry sector, under matters of this Agreement relating to the ownership and legalisation of land are dealt with both in Annex II on legality matrices, which lists specific indicators on this subject, and in Annex VIII on supplementary and support measures, under which a special land legalisation plan is established, as agreed between the parties in order to expedite legalisation as per the priorities defined in this Agreement.

The special land legalisation plan focuses on the ownership of national forest areas and protected areas. In the case of the latter, it deals only with buffer zones where forest harvesting for the State is permitted in order to ensure the necessary legal certainty and to provide the basis for the community forest-management contracts signed or due to be signed with the communities settled in those areas. It also provides for the conclusion of usufruct contracts for the users or occupiers of this land. The usufruct contract is a legal instrument that, while maintaining the State's ownership of the land, provides the occupiers with legal certainty with a view to obtaining financial, ecological and social benefits that improve quality of life and rational use of natural resources in compliance with current legislation. The purpose of these activities is to strengthen forest governance and land-use planning.

Regarding the matters of land ownership, the legalisation process and the leading role of the three institutions mentioned – the INA, IP and ICF – emphasis must be placed on coordination between them and the Honduran Institute for Coffee (IHCAFE), the goal of which is to increase the socioeconomic return generated by Honduran coffee growers by improving the competitiveness of the coffee production chain.

Coordination between these four institutions must focus on achieving an understanding of the process of issuing title deeds for coffee producers in national forest areas in a way that respects forested land, protected areas and watersheds so as to prevent the issue of

new title deeds resulting in further destruction and deterioration of the forest and the environment.

#### **4.1. Actors involved in the implementation of the LAS**

Of the government institutions directly involved in the implementation of the LAS, and in order of importance, the **ICF**, as the leader of the process, is the forestry supervisory institution acting as executor of national policy on the conservation and development of forests, protected areas and wildlife. It focuses its activities on the administration and management of forest resources, protected areas and wildlife – including protection, restoration, harvesting, conservation and promotion – to encourage sustainable development and so support the social, economic, environmental and cultural interests of the country.

The other institutions directly involved in the implementation of the LAS are listed in Section 4.2, ordered according to the number of indicators and means of verification for which they are responsible under the legality matrices, in terms of, among other aspects, registration and control of taxes, property rights, social security and the environment. The description and indicators in the legality matrices for which each institution is responsible, and the resources needed for each of them, will be described in the verification manual approved by the JIC, as established in Annex II.

The following institutions and actors are also involved in the LAS:

The judicial officers (**CSJ**) and the law enforcement authorities (national preventive police, the Honduran armed forces, **PGR and MP**) are responsible for prevention, control and law enforcement. The **IAIP** deals with matters relating to public information and transparency.

The **National Directorate of Indigenous and Afro-Honduran Peoples (DINAFROH)** reports to the Ministry of Social Inclusion (SEDIS) and seeks to improve the quality of life of the Indigenous and Afro-descendant population of Honduras through productive economic, cultural, political and social development.

**Private forestry operators** are operators performing activities along the timber supply chain, meeting the indicators in the legality matrices and filing the necessary supporting documents. They conduct the necessary and appropriate checks to ensure the legality of the timber they process, and they are subject to legality verification mechanisms implemented by the various State institutions, depending on their competencies. This group of operators includes natural and legal persons owning forest; micro, small, medium and large forestry businesses; industrial loggers; private certifying bodies; community groups, etc. These operators must also consent to social oversight by civil society organisations via the Forestry Advisory Councils in conjunction with State institutions.

**Civil society organisations** include, for the purposes of the this Agreement, Forestry Advisory Councils operating at community, municipal, regional and national levels, non-governmental development organisations, and others that are active participants in the supervision of forest resources and their impact on the population and which perform

social oversight of the activities of both authorities and operators. In order to do this, they use the procedures and protocols for handling complaints described in Section 10.3 of this Annex.

**Indigenous and Afro-descendant Peoples of Honduras**, through their management bodies and organisations, are involved in social oversight and the implementation of mechanisms and procedures for free, prior and informed consultation. They are beneficiaries of the legalisation processes for forest lands run by specialist government institutions to recognise their ancestral claim to land. When Indigenous and Afro-descendant Peoples of Honduras are involved in commercial forestry activities as operators, they are subject to LAS procedures.

#### **4.2. State institutions**

Ten government institutions are directly involved in the legality matrices of this Agreement. In order to facilitate the issuing of legal compliance certificates to all operators meeting the indicators in the legality matrices and the LAS requirements, all institutions involved in this Agreement will provide information to the ICF Legality Verification Unit on compliance with the indicators under their responsibility. This obligation also applies to the various ICF bodies.

The following is a presentation of each of the institutions involved in the legality matrices, broken down by the number of indicators and means of verification under their responsibility.

##### **4.2.1 National Institute for Forest Conservation and Development, Protected Areas and Wildlife (ICF)**

The ICF is the supervisory institution for the forestry sector; it acts as executor of national policy on conservation and development of forest, protected areas and wildlife and has the authority to formulate programmes, projects and plans and create the technical and operative administrative units necessary to fulfil the purpose and goals of Honduras's Forestry Law. It also has functions relating to the enforcement of other laws, including those on property, water and the environment.

ICF activity focuses on the administration and management of forest resources, protected areas and wildlife, including their protection, restoration, productive use, conservation and promotion, so fostering sustainable development appropriate to the country's social, economic, environmental and cultural interests.

##### **4.2.2 Revenue Administration Service (SAR)**

For the registration and control of taxes, the Revenue Administration Service (SAR) works in centralised coordination with the ICF to ensure that operators in the forestry production chain meet their tax obligations.

According to the legality matrices, the main powers of the SAR – which replaced the Management Board for Income (DEI) – are compliance with and enforcement of national and international tax regulations and management of the collection of the duties and charges established under various laws.

### **4.2.3 Municipalities**

The municipal authorities are the governance and administration bodies for their respective municipalities, and their goal is to ensure the well-being of local residents, promote integral development and protect the environment.

Municipalities have a dual role in the LAS: firstly meeting their obligations in the legality matrices as owners of municipal forest land, and secondly as local government authorities, developing and enforcing municipal taxation. The municipalities have the Tax and Finance Administration System (SAFT), a tool which, in addition to facilitating the internal control process, also provides full information on municipal finances.

### **4.2.4 Institute of Property (IP)**

The IP is a decentralised government institution with powers for the registration and identification of property and property owners throughout the entire country; as such it maintains the national register of all acts and deeds relating to registration of property and ownership, including the listing, recognition, transmission, transfer, modification, taxation and cancellation of property rights.

### **4.2.5 Ministry of Employment and Social Security (STSS)**

The STSS has overall responsibility for employment policy and social protection systems for welfare and social security for workers and employers.

### **4.2.6 Honduran Institute of Social Security (IHSS)**

The Honduran Institute of Social Security is an autonomous entity, with legal personality and its own assets, independent of the national tax authority. Since its creation, it has been responsible for guiding, directing, providing and administering social security services to the working population of Honduras. Under the Constitution of the Republic, the Government, employers and workers are obliged to contribute to the funding, improvement and expansion of the social security system.

Social security for the working class in Honduras primarily rests on the coverage offered by the IHSS, hence its major influence on governance in health and social security matters. Outside the country's main cities (Tegucigalpa, San Pedro Sula, Ceiba and Puerto Cortés) where the largest forest operators are located, the IHSS is not represented in the other population centres of the country, and even less so in rural areas, where most forest operators work.

### **4.2.7 Ministry of Energy, Natural Resources, Environment and Mines (MiAmbiente)**

MiAmbiente is responsible for the formulation, coordination, execution and assessment of policies relating to the environment, ecosystems, the protection and use of water resources, coordination, the protection of flora and fauna, and compliance with the Environmental Impact Assessment on primary and secondary forest product companies.

### **4.2.8 National Agrarian Institute (INA)**

As the INA is currently undergoing institutional restructuring, it is not yet clear where it will be located and its current functions may change in the future. Should any functions important to the LAS that are currently performed by INA be assigned to other institutions

in the future, those new institutions will be formally recorded for the purposes of this Agreement as the replacements of the INA.

The INA is a quasi-autonomous body responsible for implementing the country's farming policy, issuing title deeds for agroforestry land and providing technical assistance to rural stakeholders and Indigenous and Afro-descendant communities of Honduras, involving the rural population in the integral development of the country. The INA is responsible for registering ownership of farm land in coordination with the ICF and the IP in land ownership legalisation processes. In the particular case of ownership applications for national forest land, the INA will act in liaison with the ICF in order to maintain the use of such land for forestry; it is not its role to register ownership of forest land. A favourable ICF technical opinion is always required for assigning ownership of forest areas.

#### **4.2.9 Ministry of Agriculture and Livestock (SAG)**

The Ministry of Agriculture and Livestock coordinates the aspects relating to sectoral policies implemented by institutions making up the public agriculture sector, specifically those relating to land tenure, rural funding, trade, forestry, crop and livestock farming and rural and forest development.

The SAG is responsible for the regulation of international trade in wildlife through the application of the Convention on International Trade in Endangered Species of Wild Fauna and Flora. In the context of this Agreement, this affects timber products taken from the species covered by the CITES.

#### **4.2.10 Customs Revenue Subdirectorate (DARA)**

Executive Decree No PCM-083-2016 creates the Presidential Commission for Comprehensive Reform of the Customs System and Trade Bodies (COPRISAO). At present, during the process of comprehensive reform of the customs system and trade bodies, this commission will have direct authority over the Customs Revenue Subdirectorate (DARA).

Under the LAS, the Customs Revenue Department is involved in the control and verification of exported and imported timber products and those in transit. A thorough review of the customs procedures relating to exports, which may have an impact on verification methodology, should be completed during the preparatory and organisational phase of this Agreement in order to identify potential gaps and bottlenecks.

#### **4.2.11 Government institutions indirectly involved**

Below is a description of the government institutions indirectly connected to the LAS, i.e. they do not have full or direct responsibility or co-responsibility for the verification of the indicators in the legality matrices, yet they play a role as government control bodies, the functions of which are important to ensure the effective performance of the central government institutions and municipal authorities in relation to the LAS.

Special units, such as the National Interinstitutional Security Force (FUSINA-FFAA) and the Interinstitutional Task Force against Environmental Crime (FTIA) are operational bodies for the prosecution of environmental offences under the ENCTI. These bodies have been set up by the Government on a temporary basis and have facilitated interinstitutional coordination to halt illicit acts and enforce environmental laws. The

FTIA, in particular, comprises the ICF, MiAmbiente, judicial officers and law enforcement authorities (MP, PGR, PNP and FFAAH). It is led by the ICF and operates as an interinstitutional coordination mechanism for dealing with investigations, sanctions and monitoring, particularly for crimes with a high environmental impact. The experience gained with these bodies will serve as a model should a permanent, long-term mechanism be created. The FUSINA, meanwhile is headed by the FFAA and acts on court orders.

#### **4.2.11.1 National preventive police (PNP)**

The role of the national preventive police is to ensure that residents in Honduran territory can freely exercise their rights and freedoms by enforcing the laws and regulations on the protection of life, conservation of natural beauty and the protection of the environment, both in urban and rural areas.

Under the LAS the PNP assists in checks on the transportation of timber products, together with the ICF, judicial officers and all other law enforcement authorities. For example, the PNP operates at transit checkpoints alongside the ICF and the SAR (green checkpoints).

#### **4.2.11.2 Public Prosecutor's Office (MP)**

The Public Prosecutor's Office represents society and takes public legal action before the courts; one of its functions is to investigate environmental crimes in accordance with the current legal instruments penalising environmental acts constituting environmental crimes in Honduras, and with international treaties.

In the forestry sector the Public Prosecutor's Office acts through the Special Environmental Prosecution Service (FEMA). As representative of Honduran society, its main role consists of investigating, documenting and presenting charges before the Honduran courts in penal proceedings resulting from actions causing damage to the environment, ecosystems, natural resources and public health.

#### **4.2.11.3 Attorney-General's Office (PGR)**

The Attorney-General's Office is responsible for promoting, representing and upholding the rights of the State in all court proceedings to which it is party.

#### **4.2.11.4 Supreme Court of Justice (CSJ)**

The power to issue and enforce judgments is exclusive to the courts of the Republic. The power to impart justice falls to independent magistrates and judges.

#### **4.2.11.5 Honduran armed forces**

The armed forces are the national institution whose primary function is to defend Honduras's territorial integrity and sovereignty, to keep the peace and public order, and to uphold the Constitution.

Since 2006 the armed forces have been charged with supporting the work carried out to protect the country's forests and ecosystems; this is done through the *Dirección de Apoyo*

*al Manejo de Ecosistemas y Ambiente* (Directorate for Support of Ecosystem and Environmental Management) (C-9).

#### **4.2.11.6 National Directorate of Indigenous and Afro-Honduran Peoples (DINAFROH)**

This is the department of the Ministry of Social Inclusion that seeks to improve the quality of life of the Indigenous and Afro-descendant population of Honduras through productive economic, cultural, political and social development. With the coordination of the STSS and support of the DINAFROH, the Honduran Government is currently engaged in a process of consultation that will serve as the basis for drawing up and passing a law on free, prior, informed consultation with all the organisations of the nine Indigenous and Afro-descendant Peoples of Honduras, with the support of the UNDP and the UN Special Rapporteur.

#### **4.2.11.7 Institute for Access to Public Information (IAIP)**

The IAIP is a decentralised government body that is responsible for promoting and facilitating citizens' access to public information, and for regulating and overseeing institutional procedures for protecting, classifying and keeping public information.

Under the LAS the IAIP's responsibilities include ensuring that citizens are able to exercise their right to participate in the management of public affairs, and that there is transparency in the exercise of public functions and in the relations between the State and private individuals. Information concerning the forestry sector is published on the IAIP's single transparency portal and on the ICF portal, and is described in detail on the portal of each institution. In addition, Annex VIII includes a supplementary measure to set up a management system for information intended for the public.

#### **4.2.11.8 National Commission on Human Rights (CONADEH)**

The CONADEH monitors compliance with the rights and guarantees laid down in the Constitution of the Republic, the Universal Declaration of Human Rights and other treaties and conventions ratified by Honduras.

#### **4.2.11.9 National Research System for Forests, Protected Areas and Wildlife (SINFOR)**

SINFOR is a public-private interinstitutional platform created by the 2007 Forestry Law which organises, fosters and promotes scientific research into the forestry sector, protected areas, wildlife and the like, and encourages transfers of know-how and technology in Honduras.

Its role includes providing up-to-date information for the formulation of policies, rules and regulations that ensure sustainability and governance for the sector. In its work of planning and fostering research into forests, protected areas and wildlife, SINFOR's priority is to seek research opportunities that can be identified in national plans and strategies, such as the National Strategy for the Control of Illegal Felling and Transport of Forest Products (ENCTI), and strategic plans for each of the member institutions and other initiatives relating to the sector.

### **4.3. Private forestry sector**

Under the LAS, the private forestry-sector actors include those who, for profit, manage or produce the raw material, extract it from the forest, transport, process and place it on the market, and engage in its export and import.

Given the diversity of organisations involved and the range of their commercial activities, several classifications have been created. The Tax Code classifies them as: (i) natural persons; (ii) legal persons, which includes professional partnerships and commercial companies, cooperatives and associative enterprises and, in general, associations or entities that under public or private law have the status of legal persons; and (iii) entities, communities, organisations (Indigenous and Afro-descendant Peoples of Honduras, community groups) or legal transactions that constitute a functional or asset unit, even if they do not have a legal personality.

Another category is that arising from the number of persons working at each enterprise: forestry microenterprises, most of them set up as family businesses, employ a maximum of four people; small forestry enterprises employ 5-10 people; medium-sized forestry enterprises employ 11-100 people; and large forestry enterprises have over 100 employees.

The Forestry Law establishes three categories of company. A primary forest product company is one that carries out the initial processing of the roundwood or any other timber or non-timber raw material sourced from the forest. A secondary forest product or processing company processes products from a primary forest product company. Lastly, timber or timber-product yards place the various timber products on the market.

It should be noted that the above description applies only to the industry that uses pine timber; in the case of broadleaved timber, on the date of entry into force of this Agreement, no primary forest product companies are registered or operating in Honduras. Furthermore, the timber extracted from the forest is generally in the form of roughly squared wood rather than roundwood, because it is squared in the forest and hauled to collection points for onward transportation by motorised vehicles to the secondary industry or timber yard for sale. Stockpiles or collection centres are by definition places where timber products are stacked for subsequent transfer, with no change in their ownership. In contrast, timber yards are places where yard owners buy timber products from their suppliers and sell them to their customers.

In its routine inspections, and thanks to the social oversight reports from the Forestry Advisory Councils, the ICF will regularly monitor any changes in the forestry production chain, including pine and broadleaved forests, forest plantations or scattered trees outside forests, in order to prevent the occurrence of any forestry activities that are not covered by the LAS. If in the future there are changes in the organisation of the forestry sector as a result of the review of the applicable legal framework, the LAS will be adapted to ensure that all sources of timber are covered.



It is these operators who implement the production processes and it is therefore they who must comply with the indicators and means of verification within their individual spheres of competence. To do so, they apply adequate and relevant internal controls concerning harvesting and production licences, complying with their obligations in matters of employment, environment, taxes (both national and municipal), transportation, trade and any others specified in the various indicators. They are also required to keep proper records of the necessary supporting documents and stipulated means of verification.

Likewise, private forestry sector organisations are subject to mechanisms for verifying legal compliance that are implemented by the institutions of the State, in accordance with their competencies.

#### **4.4. Civil society organisations**

The Honduran legal framework confers on the country's citizens the right and the duty to participate in and exercise social control over actions taken by the authorities. The forestry sector contains a variety of civil society organisations (CSOs) with an interest in enforcement of the law, and they play a very active and effective part in the means of verification. These organisations are:

##### **4.4.1 Local organisations**

The Forestry Law sets up bodies for public participation, consultation and support for the ICF, such as the advisory councils on forestry, protected areas and wildlife (CCFs), which are organised and operate at local or community level, on a municipal, regional and central basis. The National Strategy against Illegal Logging (ENCTI) indicates the importance of these bodies for exercising social control, particularly at municipal and community levels, supporting verification of the management plans, annual operating plans or other types of authorisation, as well as for promoting the consumption of legal timber. This is achieved in coordination with the institutions of the State and particularly the ICF.

##### **4.4.2 Non-Governmental Development Organisations**

A variety of domestic and international non-governmental development organisations (NGDOs)<sup>7</sup> support forestry sector actions at both an institutional and territorial level. Their activities address organisation, capacity-building for public participation bodies at municipal and community level, political impact, social control, technical support and human rights, among others.

During the preparatory and organisational phase of this Agreement, the NGDOs will develop their own methodology for performing social oversight actions. The reports on this social oversight will be lodged with the Joint Implementation Committee, among other bodies, for appropriate action. This will set up a participation system that will contribute to the ongoing improvement of governance procedures established under this Agreement.

---

<sup>7</sup> Ley Especial de Fomento para las Organizaciones No Gubernamentales de Desarrollo (special law to promote non-governmental development organisations (NGDOs)), Decree No 32-2011.

A system will also be set up to deal with complaints, which will support the operation of this function of social oversight, described in Sections 1010 and 11 of this Annex.

#### **4.5. Indigenous and Afro-descendant Peoples of Honduras**

Honduras is home to nine Indigenous and Afro-descendant Peoples of Honduras. Most of these peoples live in extensive forest areas, in which both protected areas and productive forests are to be found. These peoples are: the Pech, Tawahkas, Lencas, Maya, Tolupanes, Chortís, Miskitu, Nahuas, Garífunas and English-speaking people of African origin, who have organisations that represent them, including the nationwide Confederation of Indigenous Peoples of Honduras (CONPAH).

These peoples are actors in the implementation of the LAS, including in Principle 2 of the legality matrices: 'Honduras respects the rights of the Indigenous and Afro-descendant Peoples of Honduras living in forest areas'.

In the forestry sector, the Indigenous and Afro-descendant Peoples of Honduras have the following roles:

- they are the beneficiaries of the legalisation processes and the respect for the territories ancestrally owned by them;
- they are involved in the implementation of the mechanisms and procedures for Free, Prior and Informed Consultation (FPIC) set up in order to respect the self-determination and autonomy, in accordance with ILO Convention 169 and the UN Declaration on the Rights of Indigenous and Peoples; and
- they engage in commercial activities in productive forest areas, in compliance with the legality matrices and the applicable requirements of the LAS.

#### **4.6. Capacity-building**

Capacity-building to ensure effective operation of the system and ensure the legality of timber products is described in Annex VIII. The formulation of each measure will be subject to the review of the capacity needed by all actors involved in implementing the LAS.

### **5. COVERAGE/SCOPE OF THE LAS**

All timber and timber products of Honduran origin that are covered by the LAS must be sourced from private, municipal or national forests (whether natural or planted) managed under administrative and technical criteria of maximum performance, multiple use and social equality, so as to ensure the sustainability of the ecosystems and their productive, protective and environmental capacity.

The LAS will also apply to timber from other countries when the importers of it can prove that it comes from legal sources and has been imported in compliance with the laws of

both the timber's country of origin and Honduras. All operators will be subject to the LAS, including those who have their own private certificates of forest management and chain of custody, and those who own tree plantations for commercial purposes.

### **5.1 Timber products included in the LAS.**

The LAS covers all the products defined in Annex I to this Agreement. Article 102 of the Honduran Forestry Law prohibits the export of certain timber products, stating that timber from broadleaf species from natural forests may be exported only as processed wood. The export of round or roughly squared wood of these species is therefore not permitted.

Although roundwood or roughly squared wood of these species may not be exported, it is covered by the LAS, regardless of the extent to which it has been processed.

Timber products that are not listed in Annex I to this Agreement are not subject to the FLEGT licence procedure when they are exported to the Union. In this case, Union importers of these products from Honduras must exercise due diligence in accordance with the Union Timber Regulation in order to demonstrate that they are legal.

### **5.2 Markets covered by the LAS**

The LAS will apply to timber products placed on all markets, whether export or national. However, efforts to enforce the LAS will be prioritised by distinguishing between markets as follows:

- Union market: Verification of the legality of products exported to the market of the Union will apply as stipulated in this Agreement, which considers a FLEGT licence to be a prerequisite as soon as it has been confirmed that the scheme is ready to issue FLEGT licences following the procedure laid down in Annex VII.
- Other international markets: Verification of the legality of exported products will apply as stipulated in this Agreement, regardless of the country of destination of the export, and their legality will be substantiated by means of an H-Legal licence.
- Domestic market: Verification of the legality of products placed on the domestic market will also apply as stipulated in this Agreement, and the legality of the operators that own these products will be demonstrated by means of legal compliance certificates.

In all these phases for the implementation of the LAS, measures will be adopted to prevent the entry of timber of unknown or illegal origin into the forest supply chain. The ability to implement the LAS will be enhanced by applying the measures included in Annex VIII.

### **5.3 Sources of timber covered by the LAS**

The sources of timber that are covered by the LAS are categorised as follows:

### 5.3.1 Timber harvested on the national territory

Timber harvested on the national territory comes from the following sources:

1. Forests, whether natural or plantations.
2. Areas in which agroforestry systems are established, i.e. natural or planted trees in association with other species such as coffee, cocoa or other agricultural crops.
3. Scattered coniferous or broadleaved trees outside forests.

Harvesting may be carried out in either broadleaved or pine forests, regardless of who owns the land. Harvesting is authorised in one of the following ways:

- Under a forest management plan and its annual operating plans, as approved by the ICF for:
  - Community beneficiaries who have group forest-management contracts (community forest management contracts).
  - Individual beneficiaries of forest management contracts.
  - Owners of private and municipal (ejido) forests (national and fiscal).
- Under a special plan for agroforestry systems and its annual felling plan for owners of agroforestry systems on private and municipal (ejido) land.
- Under a rescue plan for harvesting forests affected by natural disasters, pests or diseases, public or private construction works and changes of vegetation on agricultural land. Rescue plans for sites where there are to be public or private construction works or changes of vegetation on agricultural land require an environmental impact assessment before an environmental licence certificate is issued by MiAmbiente. Rescue plans linked to a change in vegetation for temporary or permanent agricultural crops apply only to agricultural land. Article 93 of the Forestry Law stipulates that the natural use of forest land must be preserved and respected in conformity with the policies and legal regulations on land-use planning. Likewise, Article 294 of the regulation for the Forestry Law forbids changes of vegetation in productive forests with management plans and on land with a high forestry potential. Section 5.3.1 of this Annex describes in greater detail the verification of timber products that are sourced from a change in land use.
- Under a recovery plan for the extraction of forestry by-products covered by an earlier licence (AOP, AFP, certified plantation harvesting licences and rescue plans).
- Certified plantation harvesting licences for the extraction of timber from forest plantations certified by the ICF.

Traditionally scattered trees outside forests, located mainly in residential and livestock areas, have been the principal source of supply of timber for carpentry shops. However, Honduras does not yet have legislation regulating the commercial harvesting of these trees, which is why a supplementary measure on this issue was included in Annex VIII. When this legislation comes into force, it will be included in the relevant indicator of the legality matrices following the procedure envisaged in the section on 'Changes to the regulatory, administrative and institutional framework of Honduras' in Annex II.

Prior to the update of the legality matrices, this source of timber will already have been included in the LAS and forestry sector operators that harvest this source of timber must apply all the other LAS requirements.

**5.3.2 Imported wood**

Both natural and legal persons that import timber must implement due diligence procedures to prove that the risk of illegal conduct concerning the imported timber is negligible and that the exporters of the country of harvesting respect the law. The scope of this due diligence procedure will be determined during the preparatory and organisational phase of this Agreement; a supplementary measure has been included in Annex VIII concerning the implementation of due diligence procedures in Honduras.

**5.3.3 Timber not covered by the Agreement**

The following two types of timber are not included in the LAS and will not be subject to the FLEGT licensing scheme:

- **Timber in transit**

Timber in transit is timber from third countries or timber that enters Honduras temporarily under a single transit declaration, the final destination of which is another country. It must be identified and kept separate from the supply chain of timber produced in Honduras or imported. Timber in transit will not be included in the LAS and therefore no FLEGT or H-Legal licence for export can be issued for it.

Section 7.5 of this Annex explains how the mechanisms to control the transit of these products will operate to ensure that they do not enter the national-market supply chain.

- **Confiscated timber**

Timber products confiscated for infringing Honduran legislation or for failing to comply with due diligence obligations in the case of imported timber are excluded from the LAS. The ICF and the security forces are empowered to conduct the necessary investigations to prosecute cases through the Public Prosecutor's Office. Section 7.6 of this Annex explains what happens to timber that is seized or confiscated.

**5.4 Scope of operators included in the LAS**

Under the this Agreement, an 'operator' is any natural or legal person that engages in activities in the forest production chain. The scope of the activities of operators covered by the LAS is described in Table.

**Table 1. Scope of activity of forestry sector operators.**

Operator	Scope of action under the LAS
1. Owner of private forest area (includes indigenous communities with land title) and common land (municipalities).	Applies for or provides evidence of land ownership. Prior to carrying out harvest activities, applies to the ICF for approval of a forest management plan and the related annual operating plans, rescue plan or recovery plan.

Operator	Scope of action under the LAS
	<p>Applies to the ICF for transport permits for the transport of harvested timber, and reports on the transport permits used, which are entered in the SIRMA database.</p> <p>Provides evidence that the FPIC principles have been followed, as appropriate.</p>
2. Owner of an area with an agroforestry system	<p>Applies for approval of an SPAS and an AFP for harvesting as part of an agroforestry system.</p> <p>Applies to the ICF for transport permits for the transport of harvested timber, and reports on the transport permits used, which are entered in the SIRMA database.</p>
3. Forest plantation owner	<p>Applies to the ICF for certification of the forest plantation and for harvesting of a certified plantation.</p> <p>Applies to the ICF for transport permits for the transport of harvested timber, and reports on the transport permits used, which are entered in the SIRMA database.</p>
4. User/Occupant	<p>Obtains an usufruct contract as a result of the land legalisation procedures that allows the user/occupant to carry out forest management activities. The requirements that must be met by private beneficiaries of the legalisation of national forest areas are laid down in the Forestry Law.</p> <p>Applies to the ICF for permission to reforest the estate or carry out other forestry/environmental activities.</p> <p>Applies for certification of the plantation and then applies for permission to harvest it.</p>
5. Usufructuary of forest areas (including community groups)	<p>In order to carry out forest management activities, applies to sign a forest management contract; and in order to harvest the forest area, applies to the ICF for approval of a forest management plan, a rescue plan or a recovery plan.</p>
6. Contractor	<p>Hired by the forest owner when the latter does not directly harvest the timber with its own resources. Harvests, hauls, and transports the timber from the forest to primary forest product companies or timber yards and may also sell it.</p> <p>Files a return with the regional forestry office on the fact that it is registered, and lists the equipment and key personnel it has for harvesting and transportation operations.</p> <p>Is responsible for using the transport permit (authorised by the ICF) and waybill (authorised by the SAR). The beneficiary or holder of a</p>

Operator	Scope of action under the LAS
	<p>harvesting licence who subcontracts a contractor is responsible for ensuring compliance with the applicable regulations.</p>
7. Carrier	<p>Provides the goods transport service, in this case that of timber, whether it be roundwood from the site of harvesting to the forest product company or timber yard, or processed timber products from the forest product company to the final destination. In general, this service is hired by the forest owner, the contractor or the forest product company.</p> <p>In the case of broadleaved forests, on the date of entry into force of this Agreement, the carrier is involved from the time when the roughly squared wood that has come from the forest has been stockpiled outside it at a collection point, and vehicles are used to transport it from there to forestry companies or timber yards.</p> <p>Submits to the authorities the documents that prove the legality of the products transported (transport permit, invoice authorised by the SAR and waybill or invoice, as appropriate).</p>
8. Qualified forestry technician (TFC)	<p>Draws up forest management plans, special plans for agroforestry systems, and related annual plans, rescue plans and recovery plans on behalf of the forest owner.</p> <p><i>(Has sole responsibility for administering the implementation of the annual operating plans of the forest management plans. For this purpose, submits to the ICF on behalf of the forest owner a memorandum of appointment and acceptance and becomes the administrator of the annual operating plan.)</i></p> <p>Is responsible for compliance with the technical standards governing any mode of harvesting that it administers. Is also responsible for submitting monthly progress reports on the transport permits used in the forest, giving detailed information about the timber extracted, supported by copies of the permits used.</p>
9. Independent forestry technician (TFI)	<p>Draws up forest management plans, special plans for agroforestry systems, and related annual plans, rescue plans and recovery plans.</p> <p>Is responsible for compliance with the technical standards governing any mode of harvesting that it administers. Is also responsible for</p>

Operator	Scope of action under the LAS
	submitting monthly progress reports on the transport permits used in the forest, giving detailed information about the timber extracted, supported by copies of the permits used.
10. Exporter	<p>Applies to the ICF for issuance of the FLEGT licence (for the Union) or the H-legal licence (for other destinations) depending on where the shipments are to be sent.</p> <p>Applies to the Customs Authority for export permits, including the commercial import invoice, the Single Customs Declaration and other documents that prove the legality of the product being exported, regarding both public health restrictions and tariff and non-tariff regulations, including CITES certificates when applicable.</p>
11. Importer	<p>Applies to the customs authority for import permits, including the commercial import invoice, the Single Customs Declaration and other documents that prove the legality of the product being imported, regarding both public health restrictions and tariff and non-tariff regulations, including CITES certificates when applicable.</p> <p>Implements mechanisms of due diligence to verify the legality of the timber product being purchased.</p>
12. Owner of a primary forest product company	<p>Keeps an up-to-date record book of inputs and outputs and files monthly production reports with the ICF, with the authorised sales invoices attached. Asks for invoices to be issued and files monthly and annual sales returns with the SAR, with the relevant authorised sales invoices and waybills attached.</p> <p>Implements mechanisms of due diligence to verify the legality of the products being purchased.</p> <p>In the case of broadleaved forests, primary forest product companies do not exist at present since the timber is roughly squared before leaving the forest and is placed on the market via secondary forest product companies or timber yards.</p>
13. Owner of a secondary forest product company (including carpentry shops and other micro, small and medium-sized enterprises (MiPyME)).	Keeps an up-to-date record book of inputs and outputs and files monthly production reports with the ICF, with the authorised sales invoices attached.



<b>Operator</b>	<b>Scope of action under the LAS</b>
	<p>Asks for invoices to be issued and files monthly and annual sales returns with the SAR, with the relevant authorised sales invoices and waybills attached.</p> <p>Implements due diligence mechanisms to verify the legality of the products being purchased.</p>
14. Owner of a timber yard	<p>Keeps an up-to-date record book of inputs and outputs and files monthly production reports with the ICF, with the authorised sales invoices attached.</p> <p>Asks for invoices to be issued and files monthly and annual sales returns with the SAR, with the relevant authorised sales invoices and waybills attached.</p> <p>Implements due diligence mechanisms to verify the legality of the products being purchased.</p>
15. Employer (of any enterprise belonging to the above categories of operators).	Registers employees with the Honduran Institute of Social Security and complies with labour legislation.

## **6. VERIFICATION OF COMPLIANCE WITH THE LEGALITY DEFINITION**

Honduran timber products are deemed to be legal on the basis of the definition of them described in Annex II.

Verification is carried out by government agencies (if appropriate using inputs provided by recognised private certification mechanisms as stipulated in Section 8 of this Annex) and consists of performing adequate checks to ensure the legality of timber products.

It must be sufficiently robust and effective to ensure identification of any non-compliance with the requirements laid down in the legality matrices set out in Annex II, in the different phases of the supply chain on the national market. The legality of timber that is imported and will enter the national chain of supply must also undergo verification.

### **6.1 Legality verification principles**

During the preparatory and organisational phase of this Agreement, the Parties, through the JIC, will update and approve a verification manual that describes the verification methodology that must be applied to check legal compliance for each of the indicators and means of verification identified as key elements for establishing the legality matrices. Each of the indicators specifies the body or unit at each institution in charge of the verification and the documents to be verified. In addition, the frequency with which the indicator is checked will be specified, and the location indicated of the records containing the information and the documents (both paper-based and digital) that are stored at the different institutions in accordance with their areas of responsibility.

#### **6.1.1 Institutions involved in legality verification**

Verification is carried out by clearly identified institutions that have adequate resources, management systems and trained personnel, together with robust and effective mechanisms to control conflicts of interest. All the verification personnel at each institution have the skills and experience necessary to perform their work and are properly supervised.

The ICF and the other institutions involved in the LAS have an organisational and functional structure to verify whether all the operators are complying with the legality Indicators. Given the volume of information that will be produced by each institution's verification of operators, and the need to record and keep this information up to date, the verification results will be entered in a database available to the ICF Legality Verification Unit. This will provide the Verification Unit on an ongoing basis with all the information necessary to be able to issue and review the validity of the operators' legal compliance certificates. The feasibility of this gathering and updating of data requires the coordination of the institutions as described in Section 11 of this Annex.

The following diagram illustrates the flow of data between the different LAS actors for the verification of legal compliance:

### MECHANISMS FOR VERIFYING LEGAL COMPLIANCE

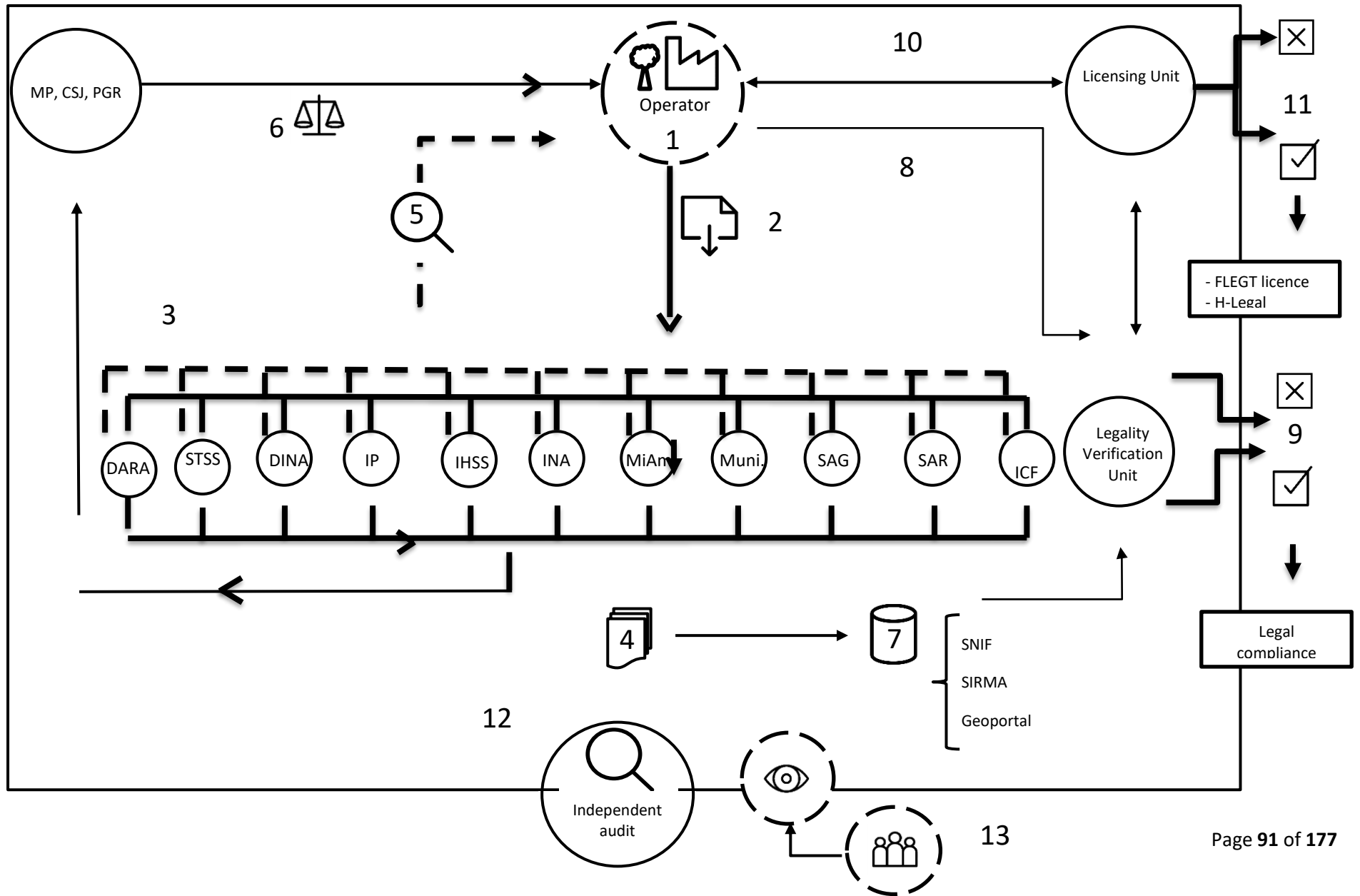

Table 2 describes the mechanisms for verifying legal compliance presented in the previous diagram.

**Table 2. Description of mechanisms for verifying legal compliance.**

No	Description
1	Forestry-sector operator: natural or legal person that carries out activities in the forest products supply chain.
2	Application for means of verification (Annex II).
3	Methodology for creation of the means of verification by each institution. Some means of verification are created only once and others are created periodically.
4	Creation of physical and/or electronic means of verification (Annex II).
5	Verification methodology. Upon identifying a case of non-compliance, each institution implements procedures to document, process, monitor and inform the database of the Legality Verification Unit.
6	Corrective or punitive action relating to legal non-compliance resulting from an administrative or ex officio action (Annex V, Section 9).
7	Compilation of joint legal compliance verification data by all institutions involved using the SIRMA, SNIF and ICF Geoportal and other tools of those institutions (Annex V, Sections 0).
8	Application to the Legality Verification Unit for a legal compliance certificate attesting to the operator's legality (Annex V, Sections 0).
9	Compilation of data held by the Legality Verification Unit in order to assess compliance with the legality matrices and control of the supply chain by the operator. If the conclusion is positive, the Legality Verification Unit issues a legal compliance certificate which proves to buyers in the domestic market that the operator has met the requirements of the LAS (Annex V, Sections 6 and 70).
10	Application to the Licensing Unit for a FLEGT or H-Legal licence attesting to the legality of the operator's activities so that the operator can export its products to any market (Annex IV).
11	Decision by the Licensing Unit on whether or not the operator is legally compliant. If the conclusion of the Verification Unit is favourable (i.e. the operator meets all the LAS requirements), either a FLEGT licence (Union market) or an H-Legal licence (other markets) is issued, proving to customers in the international market that the operator has met the requirements of the LAS. If the decision is unfavourable, the Licensing Unit notifies the applicant (operator) (Annex IV).
12	Drafting by the LAS's independent auditors of reports on their findings that include conclusions and recommendations to the Joint Implementation Committee, which is responsible for publishing these audit reports on a regular basis (Annex VI).
13	Drafting by civil society organisations of verification reports on harvesting licences and more generally on the forestry sector, which are made available to the JIC (Annex V, Section 4.4.2).

### 6.1.2 Verification procedures based on the legality matrices

The manual agreed by the Parties through the JIC will describe the methodology applied by the institutions involved, whose responsibility it is to verify part or all of the indicator. The manual will identify the body or office responsible for verification and the action it takes to perform this task. The manual will also refer to 'Verification Frequency', indicating when the means of verification are to be verified; it will also include the body and office where the paper and digital copies of this information will be stored.

### **6.1.3 Storage of the means of verifying legality**

The paper-based copies and digital files of the documents for each means of verification are kept at each institution that is responsible for creating the related means. These 'institutional' records are kept for at least 10 years, as required under the Law on Transparency and Access to Public Information (IAIP). The law also establishes the procedure for processing information (Articles 30, 31 and 32), defines what 'public information' means (Article 3) and what should be considered as confidential personal details (Article 7) or classified information (Article 8).

Given the importance of the legality and authenticity of the means of verification, the institutions responsible ensure that physical and digital records are kept for each means of verification. In the interests of the transparency and effectiveness of information management, the institutions involved in the means of verification must ensure that the information in their records is made available to other organisations – including the ICF Legality Verification Unit – in a timely and effective manner as and when it is required. Similarly, each institution linked to legality verification should avail itself of the laws, regulations and procedures that apply within its sphere of competence to seek the necessary information from operators and keep it in its records.

### **6.1.4 Information systems and verification functionalities**

The computer systems, tools and protocols that already exist and will be developed to verify compliance with the indicators in the legality matrices will make it possible to gather a set of documentary and field verifications and to reconcile the data throughout the timber supply chain. Section 3.2 of this Annex sets out the main computer tools and protocols used by the institutions involved in the LAS. The following paragraphs give a brief description of the IT systems currently in operation to support the institutions in carrying out their remits.

At the ICF:

- National Forestry Information System (SNIF).

This computer tool can be used to maintain dynamic databases on records evidencing ownership of private, national and municipal forests, and of forest product companies and timber yards. The system contains information on all the harvesting licences, including management plans, operating plans, rescue plans, recovery plans, special plans for agroforestry systems and harvesting of plantations certified by the ICF. The SNIF makes it possible to monitor the timber that flows between harvesting operators via the supply chain.

- Timber Traceability IT System (SIRMA).

This computer tool makes it possible to monitor timber extractions and transport flows based on the record of transport permits used for each harvesting licence. The system uses the information from the SNIF to keep a record of transport permits. It reconciles information on the permits registered for transport from the forest to forest product companies and on the inputs and outputs at each link of the chain by means of the monthly reports filed by each operator. The information kept on record makes it possible to monitor production, distribution or sales and stocks/inventories.

- Geoportal

This virtual platform of the forest map of Honduras shows the geographical location and surface area of the protected areas, areas assigned under management contracts, declared microbasins, road infrastructure, forest management plans and reference maps. The Geoportal is linked to the SNIF. This information is used to plot the timber flow routes and facilitates the planning of checkpoints for verification purposes on highways and at sensitive points of the road network. As and when new SNIF modules are created, they will be linked to the Geoportal: record of rescue plans, special plans for agroforestry systems, certified forest plantations and forest product companies, among others.

At the SAR:

- Electronic Internal Revenue System (E-tax)

This portal provides taxpayers with the printed forms for filing tax returns. This system makes it possible, for example, to cross-check information between monthly filings by taxpayers, i.e. income taxes, and the monthly reports that operators file with the ICF.

- Tax and Finance Administration System (SAFT)

This system enhances the efficiency, effectiveness, timeliness and transparency of municipal financial administration by means of the automated and integrated management of administrative and financial procedures based on the country's legislation. The system makes it easier to implement internal controls, handles municipal financial information on an integrated basis, and can be linked to other programs to generate statistics and digital maps.

- National Tax Register (RTN).

Natural and legal persons and organisations or entities that have no legal personality but engage in activities that make them liable to tax must register with the National Tax Register kept by the tax authorities as laid down in the applicable legislation.

In the case of natural persons, their National Tax Register number is the same as that of their National Register of Persons (RNP) number, with one extra digit, and is the same throughout their life. Legal persons must be entered in the National Tax Register when they are registered or set up.

At the IP:

- - Honduran National Property Administration System (SINAP)

This is an IT system used as the Honduran official government platform for administering information on property rights. The SINAP contains subsystems that include the SURE:

- Honduran Unified Registration System (SURE)

This is an information system designed to gradually modernise the procedure for registering property rights, ownership rights and land registration throughout the country.

At the IHSS:

- Honduran Social Security System

The IHSS operates an Information System on Members (SICA), which keeps the record of the employers and employees of enrolled enterprises. The IHSS is a nationwide system with representations and offices in all the country's major cities.

At MiAmbiente:

- Simplified Environmental Licensing System (SLAS)

This tool was designed to provide businesses with a flexible mechanism that enables them to make an immediate start on a project by supplying expeditious analysis of legal aspects that prohibit or exclude projects anywhere in the country, studying in depth the characterisation of the Environmental Impact Quotient for any type of project, and setting out automatically the migration measures required by the project in question in the geographical coordinates given for where it is to be sited.

At the INA:

- National Agrarian Register (RAN)

For the National Agrarian Register, the INA has a documentary register and geographical databases that enable it to monitor areas with title deeds. At present, it does not have an IT system or relational database architecture that enable interaction with other systems.

At the DARA:

- Automated Customs Revenue System of Honduras (SARAH).

This system uses cutting-edge technologies based on open standards that provide a highly accessible online customs service using a standard browser and web services. It also has additional applications that support customs management and make it possible to establish controls while facilitating international trade.

- Honduran Electronic System for External Trade (SECEH) and its online export declaration authorisation module

The SECEH supports the export sector by making it possible to obtain online the export documents needed for customs clearance of goods.

- International Transit of Goods (TIM) System

This IT system facilitates standardised customs procedures at Central American borders to optimise migratory, customs and quarantine formalities by means of a single document: the Single Transit Document for international goods.

- Integrated External Trade System (SICE).

This system provides external trade statistics to users at the Central Bank of Honduras (BCH) and displays information in accordance with the Central American Tariff System, doing so reliably as the information is first verified via several information sources.

During the preparatory and organisational phase of the this Agreement the following IT tools will be developed:

- Creation of a management system for the information documented at the ICF

This virtual library will enable the ICF to organise, monitor and maintain the documented information linked to the forestry sector, such as laws, central government strategy and policy documents, studies, agreements, inquiries, reports, conventions and technical document backups, among others. This system must be designed to meet the objectives of maintaining an online area where enquiries may be made and operators are given access to the documentary information to facilitate decision-making. The creation of this system will facilitate the verification procedures carried out by the ICF, which is one of

the key elements of the LAS. The objective is therefore to develop it over the short term, during the preparatory and organisational phase of this Agreement.

- Creation of a database for the Legality Verification Unit

To be able to verify operators' compliance with the indicators in the legality matrices and the requirements of the LAS, the Legality Verification Unit will need a tool to receive and update information, which provides access to actors involved in the LAS, by means of interconnection with the databases of the information systems of the institutions involved in LAS enforcement. The creation of this database will facilitate supply-chain verification and control procedures, which is one of the key elements of the LAS. The objective is therefore to develop it over the medium term, during the preparatory and organisational phase of this Agreement.

- Creation of an IT System for Forestry Registration, Administration and Control (SIRACOF)

This system is included in the results of the National Strategy against Illegal Logging (ENCTI) as a computer tool to increase the efficiency of the processing of formalities, the transparency of administrative procedures and the quality of the information in the records, and to support the control mechanisms in the forest value chain, from the forest to the processing centres and to the products' placement on the market. Significant progress has been made in developing the SIRACOF by creating and continually upgrading the systems that form its basis, since they manage, process and administer the basic information, just like the SNIF, the SIRMA and the Geoportal.

- Creation of a record-keeping system at the STSS

The STSS will need a system that will enable it to verify that operators are complying with the indicators related to its areas of responsibility.

The preparatory and organisational phase of this Agreement will offer the possibility of identifying other modules or information systems in order to continue facilitating the generation, transfer, interconnection and administration of the information concerning the verification of legal compliance in a manner that is consistent with the available financial, technical and human capacity. Requirements and capacity will be analysed in greater detail to determine what is the most appropriate degree of system computerisation in each case. This means the list of information systems for verifying legal compliance will be constantly evolving.

### **6.1.5 Risk management principle in case of non-compliance with the LAS**

Reducing unlawful practices constitutes the main challenge in implementing the LAS. It requires a comprehensive risk-management mechanism to be implemented across the entire supply chain. In cases where the authorities do not have the necessary resources to ensure effective verification in all areas with equal intensity and frequency, risk-based legality verification is an opportunity to overcome this limitation.

Risk management in implementing the LAS consists of evaluating the likelihood of the occurrence of each one of the risks and their impact on the legality of the timber. This evaluation will take into account the results of the baseline study on operators' level of compliance, which is included in Annex VIII. The nature of risk changes according to where and when it arises. For this reason, decision-making is based on an objective and



integrated methodology applied by the ICF and the other government agencies, and starts with categorising the risk and establishing the criteria for decision in accordance with the circumstances.

The verification manual under the responsibility of the JIC will present the basic principles for the categorisation of risks, which will serve as the basis for deciding how to approach legality verification; an analysis of risks of unlawful practices that could arise during the implementation of the LAS will then be given.

Risk management procedures throughout the supply chain will take into account the following unlawful practices:

- material from unknown sources and material harvested without legal logging operation rights entering any point of the chain;
- cases where the amount of a product with certain characteristics is greater than the proportion of the original product or of the amount of raw material with the same characteristics from legal sources used in the production or sale process for that type of product.

In parallel, the risk management procedures will take into account the supporting documents substantiating the legality of operators and their timber, such as recognised certificates from approved private certification systems, as defined in Section 8 of this Annex.

The actions taken to control and verify legal compliance will be based on these risk categories. Joint interinstitutional actions will be defined in order to increase the efficiency of field management by means of the interaction of the country's existing IT systems.

Thus, risk management makes it easier to formulate national strategic objectives and goals in order to tackle the challenges that require particular attention in forest governance. It also helps to evaluate whether the institutions responsible for legality verification in the timber supply chain have adequate resources, or otherwise devise actions to overcome weaknesses.

As for risk management in relation to imports, customs inspections can be carried out at border crossings or through inspection procedures completed after customs clearance in accordance with the level of risk. Inspection after customs clearance may be applied to import shipments that contain timber. In accordance with customs legislation, the customs authority will apply risk management methods to decide on the scope, content and method of post-clearance inspections of imported shipments.

Post-clearance inspection of customs dossiers and goods released must be carried out within no more than five years of the date of registration of the customs declaration. Close coordination exists between the customs authority and the ICF for the monitoring and checking of timber imports, including regular and systematised border and customs clearance checks, as well as in cases of suspected risk.

Risk management in implementing the LAS will also apply to the due diligence systems of private operators, particularly importers, in order to minimise the risk of placing illegal timber or timber products on the national market.

As defined in Section 6.2 of this Annex, the second key element of the due diligence systems will be the evaluation by each operator of the risk of the presence of illegal timber in its supply chain, based on the information gathered on the timber suppliers and taking into account the criteria laid down in the procedures to be developed during the preparatory and organisational phase of this Agreement.

The implementation of due diligence by private operators and the risk-based control procedures of the public institutions are each included in supplementary measures in Annex VIII. The procedures necessary to implement them will be drawn up, applied and validated by the JIC before the first FLEGT licence is issued.

#### **6.1.6 Legality audit resulting in a legal compliance certificate**

The ICF, via the Legality Verification Unit, will verify the legal compliance of each operator with regard to the legality indicators laid down in Annex II, the requirements concerning the supply chain set out in this Annex, which apply to each operator, following procedures that make it possible to issue a legal compliance certificate to each forestry sector operator.

The procedures for legality audits and issuance of legal compliance certificates must show that:

- The timber products have been produced in a manner that meets all the requirements included in the definition of legality. The indicators and means of verification of this definition must be complied with in accordance with the law and must attest to the operator's legality; there must be no evidence of any current infringement;
- The controls performed by the institutions involved provide assurance that the products include only timber from legal operations;
- The legality audit is carried out by the institutions involved by means of field inspections of the operators, and includes documentary control and verification of the databases available.
- A written report of this process of verification and validation is kept on file in accordance with procedures defined in the preparatory and organisational phase of this Agreement.

This process of verification will lead to the issuance of a legal compliance certificate for delivery to the applicant and will consist of the following steps:

Creation methodology:

1. The operator applies to the ICF Legality Verification Unit for a legal compliance certificate.
2. Based on the SIIAVA's annual legality audit schedule, each institution verifies the legal compliance of the operator in accordance with the applicable

- regulations under its responsibility and notifies the ICF Legality Verification Unit of the result.
3. The ICF Legality Verification Unit analyses the means of verification available to it, together with the verification reports from the institutions involved.
  4. The Legality Verification Unit evaluates whether or not the operator complies with each of the indicators in the legality matrices and with the requirements of the LAS.
  5. If the operator meets all these requirements, the Legality Verification Unit concludes the legality audit of the operator by issuing a legal compliance certificate.

#### Verification methodology:

At the request of the ICF or of any other institution with an interest, the Legality Verification Unit checks the SIRMA, SNIF or other information system to be defined during the preparatory and organisational phase of this Agreement to see whether the operator has a valid legal compliance certificate. Similarly, the existence of a valid certificate will be checked each time the operator applies to the Legality Verification Unit to renew its legal compliance certificate.

Before the legal compliance certificate expires, the operator must apply for its renewal or extension, as appropriate. When applying for an extension of the period of validity, the applicant must include supporting documents substantiating the need for an extension (e.g. if it is waiting to receive a means of verification from an institution) when its application was submitted on time and in accordance with the creation methodologies defined in a manual that will be approved by the Parties through the JIC. The Legality Verification Unit will analyse the supporting documents and determine whether it is appropriate to issue a new compliance certificate, or to renew or extend the current certificate.

As defined in Section 8 of this Annex, the procedure for issuing legal compliance certificates will take into account any recognised certificates issued under private certification systems approved by the State within the context of this Agreement. This may in fact reduce the length of the audit necessary to establish entitlement to a legal compliance certificate.

The procedures for issuing, renewing and extending the period of validity of legal compliance certificates, including the definition of the components of the administrative dossier, the operation of the system for reconciling data from the different institutions involved and the procedure for renewing legal compliance certificates will be defined in a specific ICF regulatory provision during the preparatory and organisational phase of this Agreement, and will be submitted to the JIC for approval.

## **6.2 Obligation of operators with regard to legality verification**

Forestry operators throughout the supply chain will be responsible for verifying the legality of the products that they buy by applying due diligence, as defined in Section 7.2 of this Annex.

Due diligence must be performed on purchased timber, both for the products acquired on the national market and for products that have been imported. Although the legality verification will apply to each operator, this verification must demonstrate that each timber supplier also verifies and documents the legal compliance of the timber they purchase. Information classified as confidential, such as accounting or other data, may be excluded from the due diligence exercise, as will be determined with respect to due diligence procedures during the preparatory and organisational phase of this Agreement.

For each purchase of timber at each point along the supply chain, the checks carried out by operators entail verifying its validity, authenticity and compliance with the indicators that apply to the relevant supplier, including the correlation of the physical characteristics of the timber (including species and dimensions), in order to guarantee that the timber is of legal origin. If there is any suspected risk of timber being illegal, the operators must adopt risk mitigation measures before buying timber products, as defined in Section 7.1 of this Annex.

If a supplier has a valid legal compliance certificate duly issued by the ICF Legality Verification Unit, the due diligence exercise may be limited to requesting a copy of that certificate. However, the operator must check the validity and authenticity of the legal compliance certificate using a specific Legality Verification Unit tool that will be developed during the preparatory and organisational phase of this Agreement.

Once they have gathered the information on the legal compliance of their suppliers, operators are responsible for keeping that information up to date.

The verification of compliance by forestry operators using the process of due diligence must show that:

- The products have been produced in a manner that meets all the requirements included in the definition of legality; and that
- sufficient checks are in place to ensure that the products include only timber sourced from legal operations.

## **7. VERIFICATION OF THE TIMBER AND TIMBER PRODUCT SUPPLY CHAIN**

Verification of the supply chain of timber and timber products included in this Agreement is one of the responsibilities of the ICF, which works through the SIIAVA to coordinate the other institutions involved in the LAS.

The supply chain that covers the management, production and flow of timber and timber products of both pine and broadleaved species includes the following critical points that are detailed in Appendices 1 and 2 to this Annex:

- Import of timber products
- Transit of timber products
- Forest inventory
- Harvesting of trees, production of roundwood or sawn wood, and stockpiling in the forest or collection centres

- For pine forests:
  - Transportation of roundwood from the forest to primary forest product companies.
- For broadleaved forests:
  - Transportation of sawn wood from the forest to temporary collection centres
  - Storage of timber at temporary collection centres
  - Transportation of sawn wood from temporary collection centres to primary forest product companies
- Primary forest product companies
- Transportation of processed timber products.
- Secondary forest product companies
- Timber yards
- FLEGT and H-Legal licensing
- Export of timber products
- Confiscation of timber products.

On the date of entry into force of this Agreement, the links of the broadleaved forest chain are largely the same as those of the pine forest chain. The differences that exist are described in Appendices 1 and 2 to this Annex.

### **7.1 Principles of supply-chain verification**

Control of the supply chain includes all the products covered by this Agreement, regardless of whether they are for domestic or international consumption, and covers all the links in the supply chain, from the forest inventory and management plan, through harvesting, transportation, processing, import and distribution of timber both domestically and on external markets including the Union.

To implement control of the supply chain, the ICF and other institutions involved will have available a number of automated information systems, some of them already in existence and others to be developed, which will make it possible to collect, organise, keep and transfer information, both within the forestry administration and with all the other institutions and actors involved.

These information systems will comprise tools for validating and reconciling the information to which all the institutions involved will have access and will use to verify the legality of the timber at each stage of the supply chain.

Verification of the supply chain under the LAS is based on the following two actions:

#### **a. Checking the legal compliance of the timber purchased by private actors**

The private sector plays an essential role in mitigating the risks of unlawful practices in the implementation of the LAS. The commitment of the private sector is focused on adopting a mechanism of due diligence to demonstrate the legality of the products that it purchases. Under the LAS, due diligence will be a regulated verification obligation for private operators in order to obtain information on the legal compliance of the sources of the timber that they purchase, regardless of the domestic or international origin of the

product, and analysing potential risks and implementing mitigation measures appropriate to the risks identified.

The information to be obtained on the legal compliance of timber may include documents substantiating the legality of both imported timber and timber purchased in Honduras, such as certificates issued by private certification systems recognised (following the procedure described in Section 8) by Honduras in the case of domestic timber, or FLEGT licences from the country of origin in the case of imported timber. Timber covered by such certificates and licences will automatically be deemed to pose no potential risk of illegal conduct.

The ICF will verify the operators' compliance with the due diligence requirements by carrying out legality audits which will result in the issuance of a legal compliance certificate if the operator in question is legally compliant. In this respect, the supplementary measures set out in Annex VIII include the creation of procedures and legal instruments to implement due diligence, for both the national market and the import market.

### **b. Validation and reconciliation of data for ICF control of the supply chain**

To achieve effective control of the supply chain, the information from the existing computer systems of the ICF (SNIF, SIRMA and Geoportal) and the SAR (RTN and SARAH) that are implemented and complement each other, as described in Section 6.1.4 of this Annex, will be used in an integrated manner. The combined functionalities of these systems must enable analysis by reconciliation and validation of both qualitative and quantitative data as follows:

- data submitted by forestry operators and data from field inspections entered by the ICF and other institutions (validation of data); and
- quantitative data from the different stages of the supply chain as identified in Appendices 1 and 2 to this Annex (reconciliation of data).

These reconciliation and validation functions will be carried out at each stage of the supply chain in accordance with the procedures already in place, or are to be reviewed or drawn up before the first FLEGT licence is issued.

In each of these information systems, the reconciliation of information makes it possible to identify possible irregularities and carry out audits of the forests, forest product companies and timber yards that are affected by them. In these cases, the ICF opens a file for investigation and an administrative penalty, if appropriate, although it may also report the matter to the Public Prosecutor's Office if there is evidence of criminal liability.

## **7.2 Identification of timber products**

Identifying timber products makes it easier to monitor them as they move along the supply chain. Different identification approaches are used for products from pine forests and products from broadleaved forests. Due to their physical characteristics, the identification of pine saw-logs is mainly in documentary form via the harvesting licences

and transport permits. In contrast, saw-logs of broadleaf species covered by annual operating plans are identified by enumerating and describing each original tree and saw-log obtained individually. Appendices 1 and 2 to this Annex describe in detail the type of identification throughout the supply chain.

### **7.3 Declaration of supply chain information by operators**

The timber supply chain comprises several operator types who are responsible for filing the necessary information with the competent authority as proof of legal compliance at each link in the chain. The information that each operator type must file is summarised in Table Table 1, Section 5.4, and details of it are given in Appendices 1 and 2 to this Annex.

### **7.4 Verification of imported timber products**

Verifying the legal origin of imported timber products, from the country of harvesting, is key to ensuring the integrity of the LAS supply chain. Verification of the legality of timber products imported into Honduras is based on the due diligence exercise that includes:

- a. The prohibition on importing illegal timber into Honduras, based on the national legal framework of the country or countries of origin.
- b. The responsibility of the importer to ensure the legality of the imported timber products by taking the following steps:
  - i. Collecting information on the legality of the source of the timber in the country or countries of harvesting and processing;
  - ii. Analysing the risk of illegal conduct based on the information collected under point (i); and
  - iii. Mitigating the risk identified under point (ii).
- c. The mandate of the customs authority to carry out checks on the legality of imported timber at the border point of entry of the products or, should the case arise, as an a posteriori verification, once the imported products are in Honduras.

Before the first FLEGT licence is issued, specific legislation will be drawn up concerning the verification of imported timber products, together with detailed procedures on the exercise of due diligence by private operators on imports of timber products.

### **7.5 Verification of timber products in transit**

Timber products in transit through Honduras must be identified, inventoried and kept separate from the supply chain of timber produced in Honduras or imported, and must undergo the established customs control procedures. Timber products in transit will not be a part of the LAS, and therefore they will not be able to obtain a FLEGT licence for export from Honduras.

Timber products in transit must be inspected by the Honduran Customs Authority while in transit under the classification of 'international transit of goods', which is linked to the

SARAH. The country of origin, i.e. the country where the timber was cut and harvested, must be clearly indicated on the waybill and other transport documents.

Timber products in international transit must be accompanied by their single declaration and have a traceability record at each of the customs authorities they have passed through during transit, both of which documents must record their entry into Honduras and their exit to the country of destination.

Honduras will specify the legal documents and other specific customs checks that will apply to timber products in transit during the preparatory and organisational phase of this Agreement. Before the first FLEGT licence is issued, detailed procedures will be made available on how this timber is to be treated.

### **7.6 Verification of confiscated timber products**

Under the Forestry Law, confiscated timber products are registered in the LAS, but they cannot re-enter the supply chain unless they are used exclusively for social purposes, in particular for making school furniture.

Under Article 106 of the Forestry Law, as amended, the ICF and other competent authorities (Public Prosecutor's Office, national preventive police and Honduran armed forces) are empowered to confiscate timber products or by-products that have been harvested or transported in violation of the applicable legal provisions.

Subject to an expert opinion and product-release document issued by the Public Prosecutor's Office, the ICF allocates the confiscated timber products or by-products to the country's prisons or departmental technical institutes, which must use the timber exclusively for making school furniture, which on completion must be delivered to the Ministry of Education.

The ICF will make a record of each confiscation in the LAS, entering the details of the place of confiscation, the place of origin of the timber, the name of the offender, the volume by type of confiscated timber and the shipment addressee. In this respect, a supplementary measure is included in Annex VIII to develop new specific SIRMA modules.

### **7.7 Verification of timber products sourced from land subject to a change in use**

Timber products sourced from land subject to a duly authorised change in use may enter the supply chain. Authorisation for cutting or felling all the trees on a given site may be granted in the following cases:

- a) Forests affected by natural disasters, pests or diseases. A rescue plan may be authorised only when such trees have been felled by natural causes, or seriously affected or killed by pests.
- b) Construction of public or private infrastructure. The cutting or felling of trees that need to be removed in order to build power transmission lines, aqueducts or other public or private works of public interest require an Environmental Impact



Assessment to be carried out by MiAmbiente before the ICF gives permission for the trees to be felled.

- c) Trees on agricultural land for which the owner is requesting a change of vegetation, felling and harvesting in order to use the site for livestock farming, or for establishing temporary or permanent crops. This requires an Environmental Impact Assessment to be carried out by MiAmbiente before the ICF gives permission for the trees to be felled. Such permission for tree felling linked to a change in vegetation for temporary or permanent agricultural crops only applies to agricultural land. Article 93 of the Forestry Law stipulates that the natural use of forest land must be preserved and respected in conformity with the policies and legal regulations on land-use planning. Also, Article 294 of the regulation for the Forestry Law forbids changes of vegetation on land with a high forestry potential.

The Regional Forestry Offices check that the application for the change of use is not located in areas where forest harvesting is prohibited under Article 157 of the general regulation governing the Forestry Law. If the application for change of use does not relate to such an area, the ICF authorises the felling and harvesting of the trees by issuing a 'rescue plan' harvesting licence. This is included as indicator 3.3.2 in the legality matrices. Forestry sector operators must have this rescue plan issued by the ICF before harvesting the trees, whether or not the owner intends to harvest the timber for commercial purposes.

After harvesting the trees under a rescue plan, a recovery plan may be authorised to clear the remaining trees on the site. In general, by-products such as firewood and charcoal are obtained from these recovery plans. On rare occasions, small pieces of sawn wood are obtained. These timber products may also enter the supply chain.

By law, the ICF does not issue harvesting licences for timber from areas that have already been cleared, the only exception being the case of rescue plans for timber affected by pests. If a cleared area is discovered without there being a licensed rescue plan, other than the specific case of pests, the matter will be reported to the Public Prosecutor's Office as a forestry offence. In this case the timber cannot enter the supply chain.

## **8. RECOGNITION OF PRIVATE CERTIFICATION**

In Honduras, private certification mechanisms are in place for the management of broadleaved and pine forests, plus systems for controlling the chain of custody. If they obtain the recognition and approval of the Government under this Agreement, it is appropriate that these systems for certifying forest management, chain of custody and any other such systems that may arise — whether they be international or national — by means of certificates issued by independent accredited organisations, be accepted as evidence of the legal compliance of the operators certified in order to avoid duplicating verification efforts and to expedite the issuance of legal compliance certificates to these operators.

In order for the Government to grant this recognition, a guarantee must exist that the mechanisms used by the private certification systems include all the requirements

defined in the legality matrices of this Agreement, as well as the chain of custody requirements laid down in the LAS. If the mechanisms used by the private certification systems cover only a subset of the indicators and means of verification that are defined in the legality matrices of this Agreement, the recognition and approval by the Government will only be for that subset of indicators and means of verification. The chain of custody checks performed by the private certification system must also be sufficiently consistent with the provisions of the LAS to ensure their legal compliance.

The procedure and type of recognition will be determined during the preparatory and organisational phase of this Agreement and validated by the JIC before being implemented, regardless of whether it relates to all the legality matrices or only a part of them and/or the system for controlling the chain of custody provided for in the LAS, or any other possible combination.

The principal guidelines that will be applied can be summarised as follows:

### **1. Evaluation of private certification standards**

The Government of Honduras, through the ICF, will recognise private certificates of legality, sustainable forest management and chain of custody after analysing the guidelines and criteria used and the verification procedures implemented by independent private certification organisations that are accredited by the private certification systems themselves, in order to ensure that all the requirements laid down in the legality matrices and in the LAS have indeed been included in them.

When requested to do so by a private certification system, the ICF will evaluate the guidelines, criteria and procedures applied by that system to determine whether they comply with the LAS legality matrices.

Among other things, the evaluation will also assess the ability of each certification system to provide systematic control of operators through its independent accredited organisations, and will cover more general aspects of the quality of the system, such as its transparency in providing information and data, the public availability of the audit conclusions, and the availability of an up-to-date database of holders of private certificates.

Following this assessment, a report will be drawn up, which will be published and publicly accessible.

### **2. Approval of private certification systems by the State**

If the result of the evaluation described in paragraph 1 of this section is favourable, the Executive Director of the ICF, on behalf of the State of Honduras, will publicly announce that the private certification system has been approved, specifying, if appropriate, the subset of indicators and means of verification covered by the recognition.

### **3. Recognition of certified operators by the State**

Operators that have a certificate obtained from an approved private certification system will be granted recognition by the State for the activities covered by the certificate. For other activities not included in the certificate, each operator must comply with the other obligations laid down in the legality matrices and the LAS. This recognition will be provided for the elements of the private certification system, whether this relates to legality, forest management or chain of custody, that have been assessed as compliant with the provisions of Annex II and this Annex, as described in paragraphs 1 and 2 of this section. Recognition will also be subject to analysis of the results of the private certifier's periodical audit reports for the applicant operator.

### **4. Issuance of legal compliance certificates for operators with a recognised private certificate**

Operators whose recognised private certificate covers all their activities and also all the indicators in the legality matrices will automatically obtain a legal compliance certificate issued by the ICF Legality Verification Unit. The legal compliance certificate will be issued after examining the validity of a valid legal compliance certificate that is about to expire (in the case of operators who already have such a certificate), as well as after examining the validity and authenticity of a recognised private certificate and examining the periodical audit reports of a recognised private certifier that attest to the operator's legal compliance.

If an operator's private certificate has been issued by a recognised private certification mechanism that does not cover all the requirements of the legality matrices, the legal compliance certificate will only be issued if both of the following conditions are met simultaneously:

- a. The private certifier's periodical audit reports prove the operator's compliance with the legality requirements that are common to both the private certification system and the legality matrices.
- b. The institutions involved in the LAS have verified the operator's compliance with the indicators in the legality matrices and with the LAS requirements that are not covered by the private certification system.

If an operator that holds a recognised private certificate engages in other activities outside the scope of the certificate but within the scope of this Agreement, the legal compliance certificate will be issued only if the institutions involved in the LAS verify the legal compliance of the operator's non-certified activities.

In this way legal compliance certificates can be issued to operators that have been certified under an approved private certification system, without the necessity for a specific verification mission, in order to avoid, or minimise in the case of partial recognition, duplicating verification of the operator's legality.

### **5. Lodging of private certification audit reports**

Operators with recognised private certificates must lodge with the ICF Legality Verification Unit all the audit reports drawn up by the private certification system, including the information on any change in the validity or scope of their certificates, and in particular any cases of suspension or termination of the certificates. This should make

it possible to ensure that the legal compliance of these operators is monitored, thereby permitting the future renewal of the legal compliance certificates for the operators concerned.

In turn, the recognised private certifying organisations will upload to the SNIF all the audit reports on the operators that they certify. These reports will be used by the Legality Verification Unit for information reconciliation purposes.

The procedures and guidelines for the evaluation, approval and recognition of private certification systems and of the operators certified by them will be drawn up during the preparatory and organisational phase of this Agreement. The procedures for monitoring this recognition by the Legality Verification Unit, including the monitoring of the validity of the certificates and the handling of corrective measures called for under the certification systems will also be drawn up during this phase of this Agreement. All of these documents will be made publicly available.

## **9. HANDLING OF CASES OF NON-COMPLIANCE WITH THE LAS**

The LAS lays down specific measures for identifying, registering and handling cases of non-compliance with its provisions by forestry sector actors. Non-compliance means cases in which operators in the supply chain are not in compliance with the legality matrices and the requirements of the LAS, as well as cases in which the authorities involved in the LAS fail to comply with the creation and verification procedures.

When an institution identifies during a documentary or field verification exercise a case of non-compliance with the LAS by an operator it will carry out an assessment to determine whether the non-compliance constitutes an infringement or a criminal offence. It will deal with the illegal act committed, as appropriate, by forwarding the information to the appropriate competent institution for it to impose the relevant penalties. At the same time, the competent institution will notify the ICF Legality Verification Unit so that it can either suspend or reinstate the validity of the legal compliance certificate, as appropriate.

All cases of legal non-compliance will be entered in the Legality Verification Unit's database, which will operate as a centralised archive for keeping information about and records of operator non-compliance with the requirements of the LAS and of the remedial measures or penalties linked to the resolution of these cases of non-compliance. This database will be supplied and kept up to date by all the institutions linked to the LAS requirements according to their responsibilities and spheres of competence.

When the non-compliance is classified as a criminal offence, the operator and the related shipment of timber products will not be issued with a legal compliance certificate, FLEGT or H-Legal licence, and the case will be prosecuted under the direction of the Public Prosecutor's Office. In the case of infringements, the institutions responsible will apply administrative penalties (temporary suspension of permits, fines or damage reparation), which may also prevent the issuance of a legal compliance certificate, FLEGT or H-Legal licence, at least until the infringements are rectified via measures taken to provide a solution. All cases of non-compliance that relate to a specific load must be resolved, by

means of the rectification of the situation of non-compliance and payment of the related fine, before the load to be exported is authorised, regardless of its export destination.

During the preparatory and organisational phase of this Agreement, before the first FLEGT licence is issued, all the institutions involved in the LAS will define the different categories of non-compliance with the LAS and their respective impacts on the issue and validity of a legal compliance certificate or a FLEGT or H-Legal licence. The JIC will validate this categorisation before it is applied. Also, each institution that does not yet have mechanisms for handling cases of non-compliance with the LAS will establish the necessary detailed guidelines to handle them, including the possible imposition of penalties.

To ensure coordination of the information on cases of non-compliance that is available at the different institutions, a Legality Verification Unit database will also be developed to store the information on such cases. Which of the information contained in this database will be made publicly accessible and how that will be achieved will be defined.

## **10. MECHANISMS FOR HANDLING COMPLAINTS**

### **10.1 Introduction**

The mechanisms for handling complaints will be transparent, effective, accessible and implemented by bodies that are separate from those implementing the creation and verification procedures that are defined in the legality matrices and the LAS. Mechanisms that already exist or will be set up during the preparatory and organisational phase of this Agreement will make it possible to ensure that complaints about the implementation and operation of the LAS and the organisations involved in it are handled and dealt with in accordance with the principles defined in Subsection 10.4 of this Annex.

Within the framework of these mechanisms, the term 'complaints' includes: complaints, disputes, disagreements, conflicts or any other synonym, from the actors directly involved in implementing the LAS, as well as all the actors who may be affected by the actions taken or decisions made under this Agreement.

### **10.2 Objectives**

The objectives of the complaint-handling mechanisms are as follows:

- to document, analyse and settle efficiently and in accordance with pre-established published methodologies all complaints submitted by stakeholders;
- to provide the aggrieved parties with the means to ask the institutions concerned to amend errors or omissions;
- to contribute to and strengthen the efficiency of administrative procedures; and
- to reinforce the credibility of and trust in the functioning of the LAS among the actors and the public.

The scope of each of these mechanisms will be developed during the preparatory and organisational phase of this Agreement. The procedures for the receipt, filing and handling of the complaints will be based on the principles listed in Subsection 10.4 of this

Annex and will be developed during the preparatory and organisational phase of this Agreement.

### **10.3 Types of complaint-handling mechanism**

This Agreement defines at least four types of complaint-handling mechanism, which vary according to the respective actors and spheres.

#### **1. Complaint-handling mechanisms of each institution involved in the LAS**

Each institution involved in the LAS will receive, by means of the complaint-handling mechanisms already in existence or those planned for development, complaints relating to aspects of implementation of the LAS and the conduct of operators or the conduct of the departments, services or units within each institution. In particular, each institution's mechanisms must handle complaints regarding the functions performed and the decisions made by those institutions.

If a complaint received via this mechanism is not settled within the pre-established deadline or the settlement does not meet the complainant's expectations, the complainant may lodge an appeal with the SIIAVA.

#### **2. Complaint-handling mechanism of the FLEGT Licensing Unit**

The ICF will establish, in addition to the complaint-handling mechanism mentioned in part 1 of this section, a second complaint-handling mechanism in the FLEGT Licensing Unit. This mechanism will handle complaints specific to the FLEGT and H-Legal licences that require a prompt response, such as contested decisions, undue delays and others.

If a complaint received via this mechanism is not settled within the pre-established deadline or the settlement does not meet the complainant's expectations, the complainant may lodge an appeal with the SIIAVA.

#### **3. Complaint-handling mechanism for independent audits**

The independent audit will include a mechanism to receive and handle complaints regarding its activities and findings and regarding the functioning of the LAS (verification methodology, licensing system, etc.).

If a complaint received via this mechanism is not settled within the pre-established deadline or the settlement does not meet the complainant's expectations, the complainant may lodge an appeal with the JIC. All complaints relating to the audit or to the functioning of the LAS will be submitted to the JIC for acknowledgement, analysis and registration and to define the corresponding settlement measures.

#### **4. Complaint-handling mechanism of the JIC**

The JIC will have a complaint-handling mechanism in place to deal with the problems identified by stakeholders, in particular concerning the overall commitments of this Agreement such as transparency, access to public information, improvement of governance and the impact of this Agreement on the forestry sector.

The JIC complaint-handling mechanism will also handle the appeals lodged in relation to complaints regarding the conduct of the institutions involved in the LAS framework,

FLEGT Licensing Unit and independent audit if these have not been settled at their respective levels.

#### **5. Civil society participation in complaint-handling mechanisms**

The Forestry Advisory Councils and civil society organisations will perform social oversight of the LAS and of the functioning of this Agreement in general. At the same time, they will channel and file formal and other complaints submitted by the various actors regarding the functioning of the LAS. For this purpose, they will have access to the information needed to carry out the corresponding investigations while respecting confidentiality and professional secrecy in relation to that information. To ensure proper coordination, they will enter into cooperation agreements with the ICF. The findings and recommendations of social oversight, as well as formal and other complaints, will be acknowledged and handled at the corresponding level and will ultimately be submitted to the JIC for acknowledgement and settlement.

#### **6. Participation of the CONADEH in the LAS**

Under the organic law implemented by the National Commission on Human Rights (CONADEH), all public authorities and other government institutions are obliged to support its investigations or inspections as a matter of priority and urgency. Accordingly, the CONADEH may receive complaints relating to the functioning of this Agreement and will have access to the complaint-handling mechanisms implemented by the institutions involved in the LAS and in this Agreement in general.

### **10.4 Establishment of the complaint-handling mechanisms and governing principles**

The following principles must be upheld and must be reflected in the terms of reference in order to establish the procedures and implementation of the complaint-handling mechanisms in the complaint-receiving organisations and Joint Implementation Committee:

1. All individuals and organisations, as forestry sector operators or stakeholders, or the legal representative thereof, have the right to file complaints.
2. The procedures for filing complaints must be clear, easy to understand and public.
3. The mechanisms put in place by the institutions must be easily accessible and must adequately cover the territory via offices, websites or other suitable means.
4. Forms for filing complaints must be easy to fill in and take due consideration of applicants' personal means and skills (literacy, access to the internet, etc.).
5. Complaints must detail at least the grounds of complaint and the location, date, institution and operator to which the complaint refers, as appropriate.
6. When the situation so warrants, complaints may be filed anonymously, thereby guaranteeing that the identity of the applicant remains confidential.
7. The mechanisms must avoid, to the maximum extent possible, placing time restrictions on the deadline within which a complaint must be filed.
8. The mechanisms must ensure that complaints will be dealt with as soon as they are submitted by the complainant.

9. The mechanisms must be transparent in acknowledging and following up complaints and in ensuring that complaints are addressed in a timely and appropriate manner.
10. The internal audits of each institution involved must ensure that complaints are dealt with in an appropriate manner and are not ignored.
11. Complaint files must not be commented on publicly until a decision has been made and until all parties involved, including the civil society organisations that provide them with support, have been informed of the decision.
12. The safety of the complainant, including the option of maintaining the anonymity of the complainant if appropriate, must be considered before publishing complaint files.
13. The mechanisms put in place by the institutions must document complaints and ensure that they are handled by officials different to, independent of and not under the authority of those directly involved in the original decision. The institutions must also protect officials from possible reprisals.
14. Complainants' requests must be answered or duly processed. In the case of rejection, the causes must be duly justified.
15. If a complaint is rejected or if it is not possible to settle it at the initial level, the party concerned may appeal to the level above, as defined in Section 10.3 of this Annex, and eventually to the appropriate court.

If a complaint is the product of non-compliance with the LAS, the terms described in Section 9 of this Annex will be applicable. As explained in Section 10.2 of this Annex, the procedures for the receipt, filing and handling of complaints will be based on the principles listed in this section and will be developed during the preparatory and organisational phase of this Agreement. These procedures will lay down, among other aspects, the deadlines for responding to complaints and the transparency criteria applicable to these mechanisms. The protocols and guidelines on the complaint-handling mechanisms and the actions undertaken will be submitted to the JIC.

The complaint-handling mechanisms set out above will systematically document and analyse every complaint received. The ICF and the other institutions involved will develop a specific database to document and monitor complaints within their spheres of competence. This database will be linked to the central complaints database at the ICF, as defined in Section 9 of this Annex.

The complaint-handling mechanisms will be based on close cooperation between all the parties concerned, in particular the institution that is the subject of the complaint. To this end, the ICF will enter into cooperation agreements with the public institutions involved in this Agreement, to facilitate the exchange of information and collaboration, handling and follow-up of complaints and, particularly, to ensure the transmission of information when the complaint is not initially delivered to the competent institution.

The ICF will also enter into cooperation agreements with civil society organisations interested in the functioning of the mechanism employed by the ICF to handle complaints, follow them up and publish final reports on investigation of the complaints in a coordinated manner that complements the work of the ICF and the other public institutions involved in the LAS.



The procedures, guidelines, requirements and ratings for the complaint-handling mechanisms, as well as the cooperation agreements mentioned above, will be developed and operative before the first FLEGT licence is issued.

## **11. CONSULTATION, PARTICIPATION AND COORDINATION MECHANISMS CONCERNING THE IMPLEMENTATION OF THE LAS**

Implementation of the LAS for timber products requires the participation of all the actors involved with clearly defined roles and responsibilities, pursuant to the competencies granted to them by law, in order to take full advantage of their specialisation and complementariness.

To ensure effective coordination, consultation and participation among the actors, stakeholders, State, private sector, civil society and Indigenous and Afro-descendant Peoples of Honduras, these groups agree to seek consensus on fundamental issues beyond their varying responsibilities and competencies.

This coordination can be accomplished on two complementary levels: strategic and operational. The strategic level allows for the definition of joint verification procedures while the operational level allows for the practical implementation of those procedures, in which there is no limitation on participation by the various actors.

### **11.1 Joint Implementation Committee**

This is the highest coordination body of the Honduras and the Union which, in accordance with Article 19 and Annex X to this Agreement, will be responsible for oversight and monitoring of the application of the Agreement, including management of the independent audit. The JIC shall also facilitate dialogue and exchanges of information between the Parties.

The participation of the Honduran stakeholders on the JIC will reflect the various groups of stakeholders in the Honduran forestry sector: the public and private sectors, civil society, the Indigenous and Afro-descendant Peoples of Honduras, local communities and others, where applicable.

As regards the implementation of the LAS, the JIC will be responsible for developing, approving and overseeing all the verification documents and procedures referred to in this Annex identified by the Parties during the preparatory and organisational phase and the implementation phase of this Agreement.

As provided for in Article 14 of this Agreement, the Parties will also approve, via the JIC, an implementation schedule for this Agreement. As well as an implementation timetable for the supplementary and support measures described in this Annex, this schedule will also detail the implementation steps for this Agreement as agreed by the Parties, up to the issuing of the first FLEGT licence.

## **11.2 Technical Committee**

This is the highest Honduran coordinating body and comprises all the stakeholders: public institutions, private sector, civil society and the Indigenous and Afro-descendant Peoples of Honduras. The Technical Committee is responsible for the following:

- Providing strategic input to the JIC to facilitate decision-making to support effective implementation of the FLEGT-VPA;
- Monitoring the FLEGT-VPA implementation processes based on the timetable agreed by the Parties;
- Monitoring compliance with the supplementary measures defined in Annex VIII;
- Facilitating dialogue and achieving agreement, ensuring participation by all actors connected to the FLEGT-VPA;
- Influencing the public institutions and other actors to expedite decision-making related to compliance with the FLEGT-VPA.

## **11.3 Interinstitutional Secretariat for the Implementation of the FLEGT-VPA (SIIAVA)**

At the strategic level, the State of Honduras, through an appropriate legal instrument, will create the Interinstitutional Secretariat for the Implementation of the FLEGT-VPA (SIIAVA) comprising representatives of the public sector actors linked to the LAS. This body will provide a space for dialogue and coordination that will enable the implementation of the LAS.

In the SIIAVA, public institutions will coordinate their actions in order to implement the verification mechanisms set out in Annex II and Annex V to this Agreement, and so ensure the application of the law in the specific areas included in the definition of legality and in the LAS.

These institutions must have the capacities, resources and means required to monitor and implement the LAS and must therefore build the capacity of the staff at the institutions and government departments responsible for its application. Accordingly, Annex VIII includes a specific supplementary measure on the SIIAVA.

To verify compliance with and monitoring of both application of the indicators in the legality matrices and the requirements of the LAS, the institutions forming part of the SIIAVA will report periodically to the SIIAVA and to the Technical Committee, if applicable, on the progress of development and implementation of the LAS and of the challenges encountered. The SIIAVA will take into account these periodic reports by the institutions involved in the LAS, as well as data and information on the LAS provided by these institutions' various units and information systems.

To address systematic non-compliance with the requirements laid down in Annex II and Annex V of this Agreement that results in environmental crimes, the SIIAVA will analyse the results of other mechanisms in place at the ICF and other institutions involved in the LAS. These mechanisms include mobile units and permanent checkpoints, the National Interinstitutional Security Force (FUSINA) and the Interinstitutional Task Force against Environmental Crime (FTIA), which will receive support from the national preventive police, Special Environmental Prosecution Service, the Attorney-General's Office and the Honduran armed forces, among others.

In addition, the SIIAVA will receive and will take into account the social oversight reports drawn up by the CONADEH, CCF and civil society, as well as the complaints filed by the various actors regarding the functioning of the LAS and which have not been settled by the public institutions involved in the LAS, as defined in Section 10 of this Annex. These complaints will be handled without delay and with due diligence and a response will be provided promptly.

The SIIAVA will submit the inputs provided by its public sector representatives for the preparation, organisation and implementation of this Agreement to the JIC and Technical Committee . The procedures for the operation of the SIIAVA will be laid down in precise detail in the preparatory and organisational phase of this Agreement.

#### **11.4 National Strategy against Illegal Logging (ENCTI) and its links to this Agreement**

Article 18, paragraph 22 of the Forestry Law lays down that the ICF must design and implement the National Strategy for the Control of Illegal Felling and Transport of Forest Products (ENCTI). The ICF must also 'coordinate and structure the activities of the entities representing the forestry sector, protected areas and wildlife, promoting participatory and decentralised management' (Article 18(5)).

All other institutional actors, as well as civil society organisations, forest owners, the forestry industry in its differing capacities and degrees of added value and local communities, territorial councils, advisory councils at regional, municipal and local level and other economic sectors involved in the forestry sector, will be called upon by the ICF to participate actively in the implementation of the ENCTI.

In the context of this Agreement, the implementation of the ENCTI will help with the control illegal felling and transport of forest products and will provide the ICF with an executive instrument. The results achieved and the recommendations made under the ENCTI will be submitted by the ICF to the SIIAVA, the body in which actors common to both processes participate and combine efforts, complement one another and create synergies to combat illegality in the forestry sector. Particularly relevant will be the contribution made by the Special Environmental Prosecution Service (FEMA), the Attorney-General's Office, the national police, the Honduran armed forces, the judiciary, municipalities and the National Commission on Human Rights in Honduras.

In its role in ensuring coordination between the institutions involved in this Agreement, the SIIAVA will analyse the outcomes of the ENCTI submitted by the ICF in order to address systematic environmental crimes and assign responsibilities and the actions expected of the institutions involved. It will also share information regarding the functioning of the mobile units and permanent checkpoints and the results obtained by the National Interinstitutional Security Force and the Interinstitutional Task Force against Environmental Crime.

## **12. INCENTIVE, PROMOTIONAL, SAFEGUARD AND MITIGATION MEASURES DESIGNED TO INVOLVE THE SECTOR'S VARIOUS ACTORS IN THE IMPLEMENTATION OF THE LAS**

Governance of the national forestry sector presents several challenges, which stem from, among other factors, the difficulty of ensuring the legality of the activities of the numerous forestry sector operators, including small-scale undertakings. In this respect, the implementation of the LAS will provide opportunities to address these challenges through participation by the actors in the supply chain at national level, and through identification of specific measures to strengthen and enhance legal compliance by all the actors, and thus facilitate implementation of this Agreement.

The implementation of the LAS during the preparatory and organisational phase of the VPA will take place gradually, prioritising the measures required to ensure the legality of the products destined for export. This is because many operators, especially the smaller ones, producing for the national market work informally and will probably need more time to comply fully with the national legality and LAS requirements.

Although implementation of the LAS will be scaled, the activities planned in Annex VIII, which focus on the national market, will begin in parallel to the preparatory and organisational phase of this Agreement in order to facilitate progressive legal compliance by all timber product operators in Honduras. These activities include the supplementary measures defined in Annex VIII to identify compliance bottlenecks and strengthen forestry sector operators' capacities.

A document under the responsibility of the JIC will describe supplementary measures that will be considered by the SIIAVA and the JIC to strengthen participation in implementation of the LAS by the various actors.

### Appendix 1. Links in the supply chain (pine forest)

	<b>1 Identification of the product</b>	<b>2 Declaration of data</b>		<b>3 Verification of data</b>	
		<b>2.1 Activity and responsibility</b>	<b>2.2 Data to declare</b>	<b>3.1 Validation</b>	<b>3.2 Reconciliation</b>
1. Import of timber products.	The product is identified in the Single Customs Declaration (SCD) and in the product details on the import invoice.	The importer, via the SCD and import invoice for each shipment.	For each shipment, the import invoice and the SCD include: <ul style="list-style-type: none"> <li>- Seal number.</li> <li>- Origin.</li> <li>- Importer details.</li> <li>- Description of the product (species).</li> <li>- Quantity (weight and/or volume).</li> <li>- Tariff heading.</li> <li>- Customs procedure employed.</li> <li>- Transport code.</li> </ul>	The Customs Authority systematically verifies the shipment's supporting documents and may physically check the goods against the documentation (SCD and invoice), according to the level of risk identified.	Import of timber products is one of the first links in the supply chain and data cannot be compared with previous steps.
<p>Observations:</p> <ul style="list-style-type: none"> <li>- Appropriate procedures will be established to verify and check imports of timber products under the CITES (established in conjunction with the Customs Authority, SAG and ICF).</li> <li>- Customs procedure employed: defines the final destination of the goods and is established by the importer (e.g. free zone, customs warehouse, transit, final consumption or use).</li> <li>- Transport code: defines the means of transport (type, capacity, etc.).</li> </ul>					

	<b>1 Identification of the product</b>	<b>2 Declaration of data</b>		<b>3 Verification of data</b>	
		<b>2.1 Activity and responsibility</b>	<b>2.2 Data to declare</b>	<b>3.1 Validation</b>	<b>3.2 Reconciliation</b>
2. Transit of timber products.	The product is identified in the Single Transit Declaration and in the product details on the invoice.	The importer, via the Single Transit Declaration and invoice for each shipment.	For each shipment, the invoice and the Single Transit Declaration include: <ul style="list-style-type: none"> <li>- Seal number.</li> <li>- Origin.</li> <li>- Importer details.</li> <li>- Description of the product (species).</li> <li>- Quantity (weight and/or volume).</li> <li>- Tariff heading.</li> <li>- Customs procedure employed.</li> <li>- Transport code.</li> </ul>	The Customs Authority systematically verifies the shipment's supporting documents and may physically check the means of transport against the documentation (Single Transit Declaration and invoice), according to the level of risk identified.	The Customs Authority reconciles the information on the Single Transit Declaration and recorded on entry with the information on the Single Transit Declaration at exit using the International Transit of Goods (TIM) IT tool.
<p>Observations:</p> <ul style="list-style-type: none"> <li>- Timber products in transit may not enter the supply chain.</li> <li>- Appropriate procedures will be established to verify and check imports of timber products under the CITES (established in conjunction with the Customs Authority, SAG and ICF).</li> <li>- Customs procedure employed: defines the final destination of the goods and is established by the importer (e.g. free zone, customs warehouse, transit, final consumption or use).</li> <li>- Transport code: defines the means of transport used.</li> </ul>					

	1 Identification of the product	2 Declaration of data		3 Verification of data	
		2.1 Activity and responsibility	2.2 Data to declare	3.1 Validation	3.2 Reconciliation
3. Forest inventory (In the case of National Forest Areas assigned to community groups, the owner of the land is the State of Honduras and the holder of the management plan is the corresponding community group).					
3.1. Forest inventory in annual operating plans (AOPs) under forest management plans.	Forest inventory for each felling site included in the AOP. In the field, each tree to be felled is identified by painted marks on the foot and trunk.	The holder of the forest management plan submits to the ICF the application for approval of the AOP, which contains the forest inventory.	The AOP's forest inventory includes: - geographical location and area of each felling site. - number of trees to fell and - volume to extract.	In the field inspection, the ICF performs: - Verification of the marking of boundaries in the field, comparing them against the geographic description of each felling site listed in the AOP. - Sampling of trees to be extracted and estimation of the volume per felling site, comparing them against the field data submitted in the AOP application.	The ICF reconciles the data of the AOP application with the data of the approved forest management plan's harvesting schedule.
<p>Observations:</p> <ul style="list-style-type: none"> <li>- AOPs are drawn up for areas with a forest management plan.</li> <li>Felling sites are the administrative units that make up an AOP.</li> </ul>					

	<b>1 Identification of the product</b>	<b>2 Declaration of data</b>		<b>3 Verification of data</b>	
		<b>2.1 Activity and responsibility</b>	<b>2.2 Data to declare</b>	<b>3.1 Validation</b>	<b>3.2 Reconciliation</b>
3.2. Forest inventory in annual felling plans (AFPs) under special plans for agroforestry systems (SPAS).	Forest inventory included in the AFP with details of the volume to extract by species. In the field each tree to be felled is identified by painted marks on the foot and trunk.	The holder of the SPAS submits to the ICF the application for approval of the AFP, which contains the forest inventory.	The AFP's forest inventory includes: - geographical location and area of the AFP. - number of trees to fell by species, and - volume to extract by species.	The ICF field inspection is compared against the AFP application to check: - marking of the boundaries of the AFP. - quantity of trees to fell by species, and - volume to extract by species.	The ICF reconciles the data included in the AFP application with the data included in the approved SPAS.
Observations: AFPs are drawn up for areas with an SPAS.					
3.3. Forest inventory in rescue plans.	Each tree to be felled is identified by painted marks on the foot and trunk.	The applicant submits the forest inventory in the application for approval by the ICF of the rescue plan.	The rescue plan's forest inventory includes for each tree: - geographical location - volume - species.	The ICF field inspection is compared against the information in the rescue plan application to check: 1) justified cause for rescue. 2) For each tree identified in sampling: - geographical location - volume - species.	The forest inventory is one of the first links in the supply chain and data cannot be compared with previous steps.
Observations: - Rescue plan: authorisation to harvest trees affected by natural phenomena, pests or diseases, or in cases in which construction works are required.					



	1 Identification of the product	2 Declaration of data		3 Verification of data	
		2.1 Activity and responsibility	2.2 Data to declare	3.1 Validation	3.2 Reconciliation
<p>- The ICF's capacity to carry out inspections for all rescue -plan applications when pest outbreaks occur will be expanded. For this reason, a supplementary measure is included in Annex VIII.</p>					
3.4. Forest inventory in recovery plans.	Identification of remnants of trees included under a prior harvesting licence.	The holder of a prior harvesting licence submits the recovery plan application to the ICF.	The recovery plan's forest inventory includes: <ul style="list-style-type: none"> <li>- geographical location of the area corresponding to the prior licence.</li> <li>- estimated volume of products to be extracted.</li> <li>- species.</li> </ul>	The ICF field inspection is compared against the information in the recovery plan application to check: <ol style="list-style-type: none"> <li>1) Justified cause for recovery.</li> <li>2) Geographical location of the area corresponding to the prior licence.</li> <li>3) Estimated volume of products to be extracted.</li> <li>4) Species.</li> </ol>	The ICF reconciles the data of the recovery plan application with the data of the prior harvesting licence.
<p>Observations:</p> <p>- Recovery plan: authorisation to harvest remnants of trees or by-products resulting from the following authorisations: AOP, AFP, plantation certificates and rescue plans.</p>					
3.5. Forest inventory for harvesting of forest plantations certified by the ICF.	Total inventory of trees to be felled in the certified plantation by species. Each tree to be felled is identified by painted marks on the foot and trunk.	The holder of the forest plantation certificate submits the forest inventory in the harvesting application sent to the ICF.	The forest inventory for the certified plantation includes: <ul style="list-style-type: none"> <li>- geographical location of the certified plantation.</li> <li>- quantity of trees to be felled by species, and</li> <li>- volume to extract by species.</li> </ul>	The ICF field inspection is compared against the information in the certified plantation harvesting application to check: <ol style="list-style-type: none"> <li>1) Certificate type.</li> <li>2) Marking of the boundaries of the certified plantation.</li> <li>3) Trees to be felled by species.</li> <li>4) Volume to extract by species.</li> </ol>	The ICF reconciles the information in the application submitted with the information on the approved forest plantation certificate.

	1 Identification of the product	2 Declaration of data		3 Verification of data	
		2.1 Activity and responsibility	2.2 Data to declare	3.1 Validation	3.2 Reconciliation
<p>Observations:</p> <ul style="list-style-type: none"> <li>- Two types of plantation certificate exist: CPROTE (for protection) and CPLANTA (for harvesting).</li> <li>- Annex VIII includes a supplementary measure to regulate harvesting in certified plantations.</li> </ul>					
4. Harvesting of trees, production of saw-logs and stockpiling in the forest or in collection centres.	Marking of the boundaries of the harvesting site and details of the trees to be felled in the harvesting application.	The holder of the AOP, AFP, rescue plan, recovery plan or forest plantation certificate submits the harvesting application to the ICF.	The harvesting application includes: <ul style="list-style-type: none"> <li>- geographical location of the site</li> <li>- number of trees to fell</li> <li>- volume to extract</li> <li>- road network, and</li> <li>- location of stockpiles or collection centres.</li> </ul>	The ICF field inspection is compared against the information submitted in the harvesting application to check: <ol style="list-style-type: none"> <li>1) Geographical location of the harvesting site.</li> <li>2) Road network.</li> <li>3) Location of stockpiles or collection centres.</li> <li>4) Sampling of trees felled (stumps).</li> </ol>	The ICF progressively reconciles the volume harvested with the volume authorised according to the transport permits reported using the reconciliation tools provided by the Timber Traceability IT System (SIRMA).
<p>Observations:</p> <ul style="list-style-type: none"> <li>- For each type of forest area subject to forest inventory, harvesting of trees is subject to submission of an application by the holder and approval by the ICF.</li> <li>- Stockpile or collection centre: place where timber products are stacked for later transfer.</li> </ul>					

	<b>1 Identification of the product</b>	<b>2 Declaration of data</b>		<b>3 Verification of data</b>	
		<b>2.1 Activity and responsibility</b>	<b>2.2 Data to declare</b>	<b>3.1 Validation</b>	<b>3.2 Reconciliation</b>
5. Transportation of roundwood from the forest to primary forest product companies.	The dimensions, number of pieces and volume per vehicle are detailed in the transport permit.	The holder of the harvesting licence declares in the transport permit the information relating to the products to be transported.	The following are declared in the transport permit: <ul style="list-style-type: none"> <li>- Date of transportation.</li> <li>- Origin.</li> <li>- Destination and consignee.</li> <li>- Harvesting licence identification number.</li> <li>- Number of pieces.</li> <li>- Total volume.</li> <li>- Carrier.</li> <li>- Vehicle registration number.</li> </ul>	During roadside checks, law enforcement agents verify that the contents of the load match the details on the transport permit.	The ICF progressively reconciles the transport permits declared by the holder of the harvesting licence with the transport permits declared by the forest product companies and timber yards using the reconciliation tools provided by the SIRMA.
<b>Observations:</b> <ul style="list-style-type: none"> <li>- The ICF, police, Attorney-General's Office and Honduran armed forces all participate in roadside checks.</li> </ul>					

	<b>1 Identification of the product</b>	<b>2 Declaration of data</b>		<b>3 Verification of data</b>	
		<b>2.1 Activity and responsibility</b>	<b>2.2 Data to declare</b>	<b>3.1 Validation</b>	<b>3.2 Reconciliation</b>
6. Primary forest product companies	The daily quantities are recorded by product type in the record of production volumes.	The owner of the primary forest product company, via monthly production reports based on the record of production volumes.	The monthly production report includes: i. Initial inventory of roundwood and timber products. ii. Inputs of roundwood and timber products. iii. Production volume, by type of timber product. iv. Outputs (sales or transfers). v. Final inventory of roundwood and timber products.	During the field inspection, the ICF checks the information in the forest product company's monthly production report against the information collected: 1) Calculation of production yield. 2) Comparison of inventory of existing volume against audit data.	Via the SIRMA, the ICF reconciles the inputs of roundwood and timber products declared in the monthly report with the transport permits declared by the holders of the harvesting licences.

	<b>1 Identification of the product</b>	<b>2 Declaration of data</b>		<b>3 Verification of data</b>	
		<b>2.1 Activity and responsibility</b>	<b>2.2 Data to declare</b>	<b>3.1 Validation</b>	<b>3.2 Reconciliation</b>
7. Transportation of processed timber products.	The waybill details the products to be transported per vehicle.	The carrier, via the waybill per vehicle.	The waybill per vehicle includes: <ul style="list-style-type: none"> <li>- Waybill number.</li> <li>- Date of transportation.</li> <li>- Origin.</li> <li>- Destination and consignee.</li> <li>- Number of pieces.</li> <li>- Total volume.</li> <li>- Carrier.</li> <li>- Vehicle registration number.</li> <li>- Species.</li> </ul>	During roadside checks, law enforcement agents verify that the contents of the load match the details on the waybill per vehicle.	The ICF progressively reconciles the waybills per vehicle declared by the seller with the waybills per vehicle declared by the buyer using the reconciliation tools provided by the SIRMA.
<b>Observations:</b> <ul style="list-style-type: none"> <li>- The waybill receives prior authorisation in the Revenue Administration System (SAR).</li> <li>- The ICF, police, Attorney-General's Office and Honduran armed forces all participate in roadside checks.</li> </ul>					

	<b>1 Identification of the product</b>	<b>2 Declaration of data</b>		<b>3 Verification of data</b>	
		<b>2.1 Activity and responsibility</b>	<b>2.2 Data to declare</b>	<b>3.1 Validation</b>	<b>3.2 Reconciliation</b>
8. Secondary forest product companies	Processing of timber products is entered in the record of production volumes.	The owner of the secondary forest product company, via monthly production reports based on the record of production volumes.	The monthly production report includes: i. Initial inventory of timber products. ii. Inputs of timber products. iii. Production (of timber products). iv. Outputs (sales or transfers). v. Final inventory of timber products.	During field inspections, the information provided in the secondary forest product company's monthly production report is checked against the information collected by the ICF: 1) Review of the records of inputs, production volumes and sales. 2) Inventory of existing volume.	Via the SIRMA, the ICF reconciles the data of the forest product company's monthly production report with the data of the sellers' reports on submission of authorised invoices and waybills. When the timber products come directly from the forest, the ICF reconciles the data of

	1 Identification of the product	2 Declaration of data		3 Verification of data	
		2.1 Activity and responsibility	2.2 Data to declare	3.1 Validation	3.2 Reconciliation
					the forest product company's monthly production report with the data of the transport permits declared by the licence holder.
<p>Observations:</p> <ul style="list-style-type: none"> <li>- The SAR-authorized invoice is issued when timber products are sold and accompanies the waybill throughout transportation of timber products from one link in the chain to the next.</li> </ul>					
9. Timber yard.	Movements of timber products are entered in the record of inputs and outputs.	The owner of the timber yard, via monthly reports on inputs and outputs based on the record of inputs and outputs.	The monthly report on inputs and outputs includes: <ul style="list-style-type: none"> <li>i. Initial inventory of timber products.</li> <li>ii. Inputs of timber products.</li> <li>iii. Outputs (sales or transfers).</li> <li>iv. Final inventory of timber products.</li> </ul>	During field inspections, the ICF checks the information provided in the timber yard's monthly report on inputs and outputs against the information collected: <ul style="list-style-type: none"> <li>1) Review of the record of inputs and outputs.</li> <li>2) Inventory of existing volume.</li> </ul>	Via the SIRMA, the ICF reconciles the data of the monthly report on the timber yard's inputs and outputs with the data of the sellers' reports on submission of SAR-authorized invoices and waybills.

	1 Identification of the product	2 Declaration of data		3 Verification of data	
		2.1 Activity and responsibility	2.2 Data to declare	3.1 Validation	3.2 Reconciliation
					When the timber products come directly from the forest, the ICF reconciles the data of the timber yard's monthly report on inputs and outputs with the data on transport permits declared by the holder of the harvesting licence.
<p>Observations:</p> <ul style="list-style-type: none"> <li>- The SAR-authorized invoice is issued when timber products are sold and accompanies the waybill throughout transportation of timber products from one link in the chain to the next.</li> </ul>					



	<b>1 Identification of the product</b>	<b>2 Declaration of data</b>		<b>3 Verification of data</b>	
		<b>2.1 Activity and responsibility</b>	<b>2.2 Data to declare</b>	<b>3.1 Validation</b>	<b>3.2 Reconciliation</b>
10.FLEGT and H- Legal licensing.	Declaration of the goods in the FLEGT and H-legal licence applications.	The exporter submits the FLEGT or H- legal licence application and the legal compliance certificate to the ICF Licensing Unit.	The application document contains the details of the timber products to be exported: - Commercial description of the timber or timber products. - HS Codes. - Common and scientific name of the species. - Volume (m3) and net weight (kg). - Number of units. - Distinguishing marks.	The Licensing Unit instructs the Verification Unit to check in the SIRMA or other system that the operator and all the products included in the shipment comply with the requirements of the LAS.	The ICF reconciles the information declared in the FLEGT and H- Legal licence applications: - by the primary or secondary forest product company with the data on monthly production reports, transport permits and waybills. - by the timber yard with the data on the monthly report on inputs and outputs, transport permits and waybills.
Observations:					

	1 Identification of the product	2 Declaration of data		3 Verification of data	
		2.1 Activity and responsibility	2.2 Data to declare	3.1 Validation	3.2 Reconciliation
- Reconciliation tools will be developed in the SIRMA to check FLEGT licence applications for the Union market and H-legal licence applications for other markets.					
11. Export of timber products.	The product is identified in the Single Customs Declaration (SCD) and in the product details on the SAR- authorised export invoice and BCH Export Declaration.	The exporter, via the customs agent, submits the SCD, SAR- authorised export invoice and BCH Export Declaration for each shipment.	For each shipment, the application file includes: - SAR- authorised export invoice. - SCD. - BCH Export Declaration. - FLEGT licence in the case of export to the Union. - H-legal licence issued by the Licensing Unit in the case of export outside the Union.	The Customs Authority systematically checks that the documents included in the export application are consistent with one another.	The Customs Authority checks the authenticity of the document (FLEGT or H-legal licence) on the IT systems (SIRMA and TIM).
<b>Observations:</b> - Tools will be developed to reconcile data between the International Transit of Goods System and the Timber Traceability IT system in order to verify issuance of the FLEGT licence for the European market and issuance of the H-Legal licence for other markets.					

	<b>1 Identification of the product</b>	<b>2 Declaration of data</b>		<b>3 Verification of data</b>	
		<b>2.1 Activity and responsibility</b>	<b>2.2 Data to declare</b>	<b>3.1 Validation</b>	<b>3.2 Reconciliation</b>
12. Confiscation of timber products	Confiscation order issued by the Public Prosecutor's Office (MP), accompanied by the expert opinion providing details of the timber product.	The ICF, with the support of the security forces (national preventive police and Honduran armed forces) confiscates the timber products. The MP, with technical assistance from the ICF, immediately prepares the preliminary evidence and issues the expert opinion.	The expert opinion includes: <ul style="list-style-type: none"> <li>- Commercial value of the timber product.</li> <li>- Characteristics of the timber product.</li> <li>- Place of origin, if known.</li> <li>- Quality or condition of the timber product.</li> </ul> The confiscation order issued by the MP includes: <ul style="list-style-type: none"> <li>- Name of the offender.</li> <li>- Quantity (weight and/or volume).</li> <li>- Species.</li> <li>- Type of timber product.</li> </ul>	The ICF checks the timber product delivered against the expert opinion issued by the MP.	The ICF reconciles the information declared in the confiscation order with the information submitted and other information related to the owner and origin, doing so using the reconciliation tools provided by the SIRMA.
<b>Observations:</b> <ul style="list-style-type: none"> <li>- Confiscated timber products may not enter the supply chain.</li> <li>- The SIRMA contains a module that allows users to record transport permits of confiscated timber.</li> <li>- Section 7.6 of this Annex describes how confiscated timber products are handled.</li> </ul>					



## Appendix 2. Links in the supply chain (broadleaved forest)

0 Critical control points	1 Identification of the product	2 Declaration of data		3 Verification of data	
		2.1 Activity and responsibility	2.2 Data to declare	3.1 Validation	3.2 Reconciliation
1. Import of timber products.	Similar to pine forest.	Similar to pine forest.	Similar to pine forest.	Similar to pine forest.	Similar to pine forest.
2. Transit of timber products.	Similar to pine forest.	Similar to pine forest.	Similar to pine forest.	Similar to pine forest.	Similar to pine forest.
<b>3. Forest inventory</b> (In the case of National Forest Areas assigned to community groups, the owner of the land is the State of Honduras and the holder of the management plan is the corresponding community group).					
3.1. Forest inventory in annual operating plans (AOPs) under forest management plans.	Forest inventory for each annual felling site, included in the AOP. In the field, each tree to be felled is numbered and identified by painted marks on the foot and trunk.	The holder of the forest management plan submits to the ICF the application for approval of the AOP, which contains the forest inventory for 100 % of the trees to be extracted from each annual felling site.	The AOP's forest inventory includes a volumes matrix that details the following for each tree: - tree number, - volume - species.	In the field inspection, the ICF selects a sample of the trees marked in the field and checks them against the AOP application. For each tree identified, ICF checks the following: - number - volume - species	The ICF reconciles the data of the AOP application with the data of the approved forest management plan's harvesting schedule.
<b>Observations:</b> - - AOPs are drawn up for areas with a forest management plan. - Felling sites are the administrative units that make up an AOP.					

0 Critical control points	1 Identification of the product	2 Declaration of data		3 Verification of data	
		2.1 Activity and responsibility	2.2 Data to declare	3.1 Validation	3.2 Reconciliation
3.2. Forest inventory in annual felling plans (AFPs) under special plans for agroforestry systems (SPAS).	Similar to pine forest.	Similar to pine forest.	Similar to pine forest.	Similar to pine forest.	Similar to pine forest.
Observations: - AFPs are drawn up for areas with an SPAS.					
3.3. Forest inventory in rescue plans.	Similar to pine forest.	Similar to pine forest.	Similar to pine forest.	Similar to pine forest.	Similar to pine forest.
Observations: - Rescue plan: authorisation to harvest trees affected by natural phenomena, pests or diseases, or in cases in which construction works are required.					
3.4. Forest inventory in recovery plans.	Similar to pine forest.	Similar to pine forest.	Similar to pine forest.	Similar to pine forest.	Similar to pine forest.
Observations: - Recovery plan: authorisation to harvest remnants of trees or by-products resulting from the following authorisations: AOP, AFP, plantation certificates and rescue plans.					
3.5. Forest inventory for harvesting of forest plantations certified by the ICF.	Similar to pine forest.	Similar to pine forest.	Similar to pine forest.	Similar to pine forest.	Similar to pine forest.

0 Critical control points	1 Identification of the product	2 Declaration of data		3 Verification of data	
		2.1 Activity and responsibility	2.2 Data to declare	3.1 Validation	3.2 Reconciliation
<p>Observations:</p> <ul style="list-style-type: none"> <li>- Two types of plantation certificate exist: CPROTE (for protection) and CPLANTA (for harvesting).</li> <li>- Annex VIII includes a supplementary measure to regulate harvesting in certified plantations.</li> </ul>					
4. Harvesting of trees and production of roundwood and sawn timber.	Marking of the boundaries of the harvesting site and details of the trees to be felled in the harvesting application.	The holder of the AOP, AFP, rescue plan, recovery plan or forest plantation certificate submits the harvesting application to the ICF.	<p>The harvesting application includes:</p> <ul style="list-style-type: none"> <li>- geographical location of the site</li> <li>- geographical coordinates of the trees to be harvested.</li> <li>- number of trees to fell</li> <li>- volume to extract</li> <li>- geographical location of the stockpiles.</li> </ul>	<p>The ICF compares information from field visits against the information submitted in the harvesting application:</p> <ol style="list-style-type: none"> <li>1) Geographical location of the harvesting site.</li> <li>2) Sample of trees harvested (number, species).</li> </ol>	<p>The ICF progressively reconciles the volume harvested with the volume authorised according to the transport permits reported using the reconciliation tools provided by the Timber Traceability IT System (SIRMA).</p>
<p>Observations:</p> <ul style="list-style-type: none"> <li>- For each type of forest area subject to inventory, harvesting of trees is subject to an application by the holder and approval by the ICF.</li> <li>- Harvesting of mahogany and cedar requires compliance with the provisions of Ministerial Agreement ICF-047-2011 implementing a chain of custody for mahogany and cedar sourced from natural forests.</li> </ul>					
5. Transportation of sawn wood from the forest	Some harvesting operators make use of locally available transport systems (e.g. manpower, river or animal) to move the sawn wood from the harvesting site to the temporary collection centres because of the lack of roads suitable for vehicles.			A supplementary measure in Annex VIII provides for a special regulation governing transport (by	

0 Critical control points	1 Identification of the product	2 Declaration of data		3 Verification of data	
		2.1 Activity and responsibility	2.2 Data to declare	3.1 Validation	3.2 Reconciliation
to temporary collection centres.				river, mule, etc.) from the forest to the collection centre.	
6. Storage of timber at collection centres.	The timber transported is stored at a collection centre and the volume of each species is recorded. This is the information used when applying to the ICF for transport permits.			A supplementary measure in Annex VIII provides for a special regulation governing storage at the collection centre.	
7. Transportation of roundwood and sawn timber from temporary collection centres.	Similar to link 5.	Similar to link 5.	Similar to link 5.	Similar to link 5.	Similar to link 5
<p>Observations:</p> <ul style="list-style-type: none"> <li>- The ICF, police, Attorney-General's Office and Honduran armed forces all participate in roadside checks.</li> <li>- Sawn wood transported from temporary collection centres or forest stockpiles is considered raw material and is transported under a sawn-wood transport permit.</li> <li>- The supply chain concludes at this link if the roundwood or sawn wood is purchased by a final consumer.</li> <li>- A supplementary measure is included in Annex VIII to create a special regulation establishing control mechanisms for transportation (by river, mule, etc.) from the forest to collection centres and for storage at these centres.</li> <li>- Temporary collection centres are strategically located in places either in the forest or outside it accessible by road or river.</li> </ul>					
8. Primary forest product companies	Similar to pine forest.	Similar to pine forest.	Similar to pine forest.	Similar to pine forest.	Similar to pine forest.
9. Transportation of processed timber products.	Similar to pine forest.	Similar to pine forest.	Similar to pine forest.	Similar to pine forest.	Similar to pine forest.



0 Critical control points	1 Identification of the product	2 Declaration of data		3 Verification of data	
		2.1 Activity and responsibility	2.2 Data to declare	3.1 Validation	3.2 Reconciliation
Observations: <ul style="list-style-type: none"> <li>- The waybill receives prior authorisation in the Revenue Administration System (SAR).</li> <li>- The ICF, police, Attorney-General's Office and Honduran armed forces all participate in roadside checks.</li> <li>- Processed timber means timber processed by a forest product company and excludes sawn wood held in temporary collection centres or forest stockpiles.</li> </ul>					
10. Secondary forest product companies	Similar to pine forest.	Similar to pine forest.	Similar to pine forest.	Similar to pine forest.	Similar to pine forest.
11. Timber yard.	Similar to pine forest.	Similar to pine forest.	Similar to pine forest.	Similar to pine forest.	Similar to pine forest.
12. FLEGT and H-Legal licensing	Similar to pine forest.	Similar to pine forest.	Similar to pine forest.	Similar to pine forest.	Similar to pine forest.
13. Export of timber products.	Similar to pine forest.	Similar to pine forest.	Similar to pine forest.	Similar to pine forest.	Similar to pine forest.
14. Confiscation of timber products	Similar to pine forest.	Similar to pine forest.	Similar to pine forest.	Similar to pine forest.	Similar to pine forest.

## **Annex VI Independent audits**

### **1. INTRODUCTION**

This Annex describes the procedure for carrying out an independent audit<sup>(8)</sup> of Honduras's Legality Assurance System for Forest Products - LAS (Sistema para Asegurar la Legalidad de los Productos Forestales de Honduras) under this Agreement. The independent audit will check that the mechanisms implemented within the LAS to demonstrate the legality of logging, importing, processing, transport and trade in forest products are functioning and meet supply-chain requirements and the provisions laid down by the FLEGT licensing authority.

This Annex sets out a list of tasks and a protocol for gathering information and reporting. It also describes the qualifications required of the independent auditor, and a list of primary sources of information.

### **2. OBJECTIVES**

The objectives of the independent audit are to:

- a) evaluate the efficiency and effectiveness of the LAS, and
- b) propose any adjustments to implementation of the LAS that may prove necessary.

### **3. TASKS**

The independent audit will evaluate legal compliance in all aspects addressed in the Annexes II, IV and V (LAS).

Of key importance are the checks to ensure that the legality definition is adhered to in practice, that products in the value chain are traceable and that there is verification prior to the issuing of a FLEGT licence. The method will be evidence-based and include documentary checks and on-the-spot visits.

Specific tasks of the independent audit will be to:

- a) check that systems are functioning effectively and that timber harvested, transported, processed and marketed, including imported timber, complies with the legal requirements. This includes legal requirements concerning approval of the harvesting of timber, upholding the rights of the Indigenous and Afro-descendant Peoples of Honduras, compliance with employment and safety obligations, transport, processing, trade, and payment of taxes, fees and tariffs;
- b) verify that traceability, a key component of the LAS, is effective and functioning satisfactorily, confirming that requirements are fulfilled from the time of pre-harvesting operations to export or sale on the domestic market;

---

<sup>(8)</sup> The independent auditing of this Agreement is separate from independent forest monitoring and may complement the work of other social oversight bodies within the country.

- c) evaluate the performance and effectiveness of the ICF's Legality Verification Unit, in its role of verifying legality, and of the associated government agencies involved in the verification process to ensure compliance with LAS requirements;
- d) evaluate the system established to ensure that the ICF's FLEGT Licensing Unit issues FLEGT or H-Legal licences only to consignments which are produced, processed, transported and exported in full compliance with the applicable indicators in the legality matrices and the LAS;
- e) assess the process for determining the validity of FLEGT and H-legal licences in order to ensure that the verification system is efficient and does not unduly delay or burden the licence-holder;
- f) evaluate how reported breaches are addressed by the competent authorities and whether they are dealt with promptly;
- g) evaluate the effectiveness of any measures taken to correct problems identified in the process;
- h) identify gaps and weaknesses in the overall LAS by studying the functioning of the traceability system, legal compliance and verification of the FLEGT and H-legal licensing components, together with the impact on the credibility of the LAS;
- i) check and evaluate implementation of the safeguard measures described in the LAS or others adopted later, and make recommendations;
- j) draft and report its findings, including conclusions and recommendations to the Joint Implementation Committee (JIC), which is responsible for publishing these independent audit reports regularly.

#### **4. METHODOLOGY: METHODS FOR GATHERING AND ASSESSING INFORMATION AND REPORTING**

The independent audit will be conducted under the responsibility of an independent body of proven professionalism and integrity in the discharge of its responsibilities. The audit body will prepare a manual of procedures setting out the methods for gathering information, assessing evidence and reporting. The manual proposed will be reviewed and approved by the JIC.

The audit body must use the procedures established in the manual to conduct its various activities, including field visits and investigations, to seek feedback from stakeholders, document its findings and recommendations and draw up reports for the JIC for subsequent publication.

##### **4.1. Work schedule**

- a) In the first year of operation of the FLEGT licensing scheme, the independent audit body will conduct a phased, interactive audit;
- b) In the next two years, the audit body will conduct at least one annual audit of the LAS. Subsequently, the Parties will evaluate whether the annual frequency should be maintained;
- c) The audit body may also conduct impromptu audits and spot checks, or conduct them at the request of one of the Parties.

## **4.2. Scope of work**

- a) The work of the independent audit body will cover all aspects of the LAS, including compliance with the legality definition, the traceability system, verification and licensing, and any certification scheme that the Government has approved as providing evidence of compliance with the LAS.
- b) The audit body will audit compliance with the indicators in public institutions and private companies responsible for various aspects of the LAS.
- c) The independent audit body must check the systems implemented by Union competent authorities to verify FLEGT licences issued by Honduras.

## **4.3. Evidence gathering**

The independent audit manual of procedures will set out the procedures and practices for gathering evidence, which will include on-the-spot checks, investigations, interviews, documentation and how the independent auditor responds to complaints.

## **4.4. Evaluation**

In the course of its investigations the independent audit body will ensure that evidence is evaluated in accordance with ISO 19011 or an equivalent standard agreed by the JIC.

## **4.5. Audit systems**

In documenting audit evidence in order to diagnose failings and infringements in any part of the LAS and in following up any corrective action taken, the independent auditor must:

- a) keep appropriate records of audit evidence detailing performance, compliance, non-performance and non-compliance, with respect to the LAS;
- b) record and evaluate a sample, selected on the basis of risk assessment, from a point where non-performance or non-compliance with any aspect of the LAS has been detected, including FLEGT licensing requirements, and the action taken to address the non-performance or non-compliance;
- c) record weaknesses and gaps in the LAS, identifying areas for correction and improvement;
- d) record and evaluate the effectiveness of all corrective measures implemented by the parties concerned, including the ICF, and other public authorities and private bodies responsible for other aspects of the LAS.
- e) evaluate the implementation of and compliance with safeguard measures.

## **5. REPORTS AND DISSEMINATION**

5.1. The independent audit body will draw up its reports in accordance with the format and protocol agreed with the JIC. It must:

- a) report on its activities in accordance with the work schedule agreed with the JIC;
- b) draw up its reports in accordance with internationally accepted auditing principles, as specified in its agreement with the JIC;
- c) present all reports to the JIC, which will comment on them;
- d) draw up final reports which reflect the JIC's comments.

5.2. Reports approved by the JIC will be considered public documents and must be published on the Parties' websites.

## **6. SOURCES OF INFORMATION**

Primary sources of information will include document reviews, on-the-spot visits and consultations/meetings with relevant stakeholders listed in the legality matrices (Annex II).

The Government of Honduras and the Union will ensure that the audit body has access to all necessary information, including documents and databases that it deems relevant, especially those that are needed to evaluate the effectiveness of systems established to verify compliance with the LAS. This will include access to information produced and/or held by branches and agencies of the public authorities, and by private bodies recruited by those public authorities.

The audit body must also have full access to all forest management areas before, during and after forest operations. This will include access to forests with logging permits, primary forest industries, processing industries, timber yards and export points. This broad access is designed to enable the independent auditor to uncover weaknesses wherever they exist in the LAS.

Specifically, the audit body must have access to government agencies and other bodies appointed or recruited by the Government to perform functions related to any part of the LAS, plus any other parties which may be able to provide relevant information. These include:

### **6.1. Government of Honduras and bodies appointed by the Government**

- a) the ICF, through the regulatory departments referred to in Annex V; the General Secretariat and the regional and local forestry offices of the ICF involved in various aspects of forestry activity covered by this Agreement;
- b) the Independent Forest Monitoring (IM) specialist body, which issues reports on monitoring activities of different parts of the production chain that it carries out at national level;
- c) public institutions and their subordinate bodies involved in the implementation of the LAS and law enforcement referred to in Annex V, such as: MiAmbiente, SAG, Public Prosecutor's Office and the High Court of Auditors, including the ICF internal audit department, SAG, SEFIN, INA, IP, SAR, IHSS and STSS, among others.

### **6.2. Civil society, local communities and Indigenous and Afro-descendant Peoples of Honduras**

- a) Local, national, regional and international civil society organisations involved in monitoring forestry activities in Honduras.
- b) Communities and individuals involved in managing forestry activities.
- c) Community forestry management bodies, such as the advisory councils concerned at national, departmental, municipal and community levels, and other bodies involved in various aspects of the forestry sector.
- d) Organisations of Indigenous and Afro-descendant Peoples of Honduras.

### **6.3. Other sources**

- Forestry companies
- Agro-forestry groups
- Forest owners
- Academic institutions
- Local authorities (municipalities, water boards, trusts, etc.)
- Private forest-certification bodies and findings of the reports on private certification processes
- National Forestry Association
- Importers and exporters of forest products
- Stakeholders that register a complaint or request an impromptu audit of certain aspects of the LAS
- Other sources that the independent auditor considers relevant.

## **7. QUALIFICATIONS REQUIRED**

The applicant independent audit body must demonstrate integrity and have a track record of conducting similar audits, and have the capacity to conduct systematic analysis. The audit body must be credible and be independent from Honduran operators and Honduran institutions that have a commercial or regulatory role in the forestry sector.

It is the responsibility of the applicant audit body to ensure that its personnel declare any potential conflict of interest and, where such conflicts exist, to explain what measures it will take to mitigate them. In addition, the applicant audit body must also meet the following requirements:

- a) have a documented internal quality management system that meets the requirements of ISO 17021<sup>(9)</sup>, or equivalent standards and conduct audits in accordance with procedures that meet ISO 19011<sup>(10)</sup>, or equivalent standards;
- b) have experience in audits of management systems;
- c) have a method and mechanism for transparently handling complaints and grievances;
- d) have a range of skills in addition to auditing, preferably in forest management, and sufficient expertise and experience in performing similar functions in other parts of the world, preferably in Latin America;;
- e) demonstrate that it has a team of experts with experience of Honduras or other parts of Latin America. The involvement of experts from the region alongside international experts should be encouraged;
- f) have a thorough understanding of the commercial forestry sector, preferably in Central America;
- g) have personnel with expertise in various fields of forestry, including forest management, processing, traceability and international trade in timber and timber products.

The independent auditor may consider a partnership or joint venture with a Honduran organization.

## **8. SELECTION PROCESS AND INSTITUTIONAL ARRANGEMENTS**

---

<sup>(9)</sup> ISO/CEI 17021:2006. Conformity assessment - Requirements for bodies providing audit and certification of management systems.

<sup>(10)</sup> ISO 19011:2002. Guidelines for quality and/or environmental management systems auditing.

The applicant audit body will be recruited by competitive bidding open to national and international entities in accordance with Honduran law. On the basis of the above terms of reference, subject to the needs of the tendering process, more specific terms of reference may be drawn up by the JIC. It is the responsibility of the Government of Honduras to initiate the recruitment and selection of the body to carry out the independent audit, on the basis of the JIC's recommendations.

Tender evaluation must be transparent and all stakeholders informed of the criteria that will be applied. An entity designated by Honduras that is a member of the JIC will sign the contract with the body selected to carry out the independent audit of the LAS, after consultation with the Union. Due diligence conducted on the competing entities and the tender evaluation report will be made public.

## **9. OTHER RESPONSIBILITIES**

This section covers additional responsibilities of the body selected to carry out the independent audit, which include the following:

### **9.1. Accessibility**

The body contracted to carry out the independent audit is expected to have a contact point or representative in Honduras so that it is accessible to the Government, private sector, civil society organisations, Indigenous and Afro-descendant Peoples of Honduras and other stakeholders.

### **9.2. Capacity-building and sustainability**

The body contracted to carry out the independent audit must also:

- a) engage with government agencies, the private sector, civil society and the Indigenous and Afro-descendant Peoples of Honduras in ways that enable Hondurans to acquire a clear understanding of the independent auditor's work, for example by means of training workshops or briefing sessions;
- b) recruit qualified Honduran staff and build their individual capacity to conduct independent audits of the LAS.

## Annex VII

### CRITERIA FOR EVALUATING THE HONDURAN LEGALITY ASSURANCE SYSTEM (LAS) FOR TIMBER PRODUCTS

This Agreement provides for the development and implementation of the Honduran Legality Assurance System (LAS) for timber products to ensure that all timber products specified in Annex I and exported from Honduras to the European Union, or sold on other export or national markets, have been legally produced. The LAS should include the following:

- 1) the *definition of legal timber and timber products given in the Legality Matrices in Annex II* to indicate the laws and regulations to be complied with when issuing a legal compliance certificate, a FLEGT licence or an H-Legal licence;
- 2) *supply-chain controls* to track timber from forest operations or the point of import to the final domestic market or point of export;
- 3) *verification procedures* to ensure and document compliance with all aspects of the Legality Matrices and supply chain controls;
- 4) *legality verification procedures* when issuing legal compliance certificates for national market, FLEGT or H-Legal licences for export markets;
- 5) *independent audits* to ensure that the system is as effective and efficient as it should be.

The LAS will be subject to an independent audit before the licensing scheme becomes fully operational; its terms of reference will be jointly agreed between the Parties through the Joint Implementation Committee (JIC). These assessment criteria set out what the LAS system is expected to achieve and will provide the basis for the terms of reference for the audit with the aim of:

- i. reviewing the system description with special focus on any changes to be made upon signature of this Agreement,
- ii. examining the functioning of the system in practice, and
- iii. analysing the ability of operators and public bodies to implement the LAS.

#### **Section 1: Definition of legality**

For the purposes of this Agreement, the definition of legal timber is the one given in Annex II.

Legal timber is defined on the basis of the laws and legal instruments in force in Honduras at the time of issuing the FLEGT licences. The definition used must be unambiguous, objectively verifiable and operationally workable, at least for the laws which regulate the following areas:

**Felling and harvesting rights:** allocating legal rights to felling and harvesting/extracting timber in a legally determined area with an ICF (Forest Conservation Institute) authorisation.



**Forestry operations:** complying with legal requirements for forest management, in particular compliance with the relevant environmental and labour laws at all stages of the forest-products supply chain.

**Fees and taxes:** paying legally established fees and taxes on timber imports, at municipal and national level, as a prerequisite for obtaining felling, harvesting, transport, large-scale production, processing and marketing rights for timber.

**Other users:** respecting other parties' tenure or rights to use land and other natural resources, where such rights may be claimed by other parties who may be affected by the felling and harvesting of timber and other natural resources.

**Trade and customs:** complying with legal requirements and trade and customs procedures, including paying import tariffs on forest products and export duties.

**The audit of the LAS should include the following questions:**

- 1.1. Is it clear what legal instrument underpins each element of the Legality Matrices?
- 1.2. Is it clear what legal instrument and specific rules support each principle, criterion and indicator in the Legality Matrices?
- 1.3. Are the criteria and indicators to be used to check compliance with each element of the Legality Matrices specified?
- 1.4. Are the means used to check whether each principle, criterion and indicator in the Legality Matrices has been complied with based on documented and valid legal instruments?
- 1.5. Are the criteria and indicators clear, objective and operationally workable?
- 1.6. Do the criteria and indicators, and the methodology for establishing and checking them, clearly identify the roles and responsibilities of the various stakeholders? Can the checks be used to assess the performance of all the stakeholders?
- 1.7. Do the Legality Matrices include the main areas of existing law (felling and harvesting rights, forestry operations, fees and taxes, other users, trade and customs? If not, why were certain areas of law omitted from the Legality Matrices?
- 1.8. Do the Legality Matrices include all possible sources of timber that enter the supply chain? Have appropriate indicators been developed for the different allocation procedures for sources or rights?
- 1.9. When the Legality Matrices were drawn up, did the parties concerned take into account all the main areas of applicable law?
- 1.10. Does the Legality Assurance System include the main legal provisions identified through discussions among the parties concerned?
- 1.11. Have the Legality Matrices and enforcement matrix been amended since the entry into force of the Voluntary Partnership Agreement between the European Union and the Republic of Honduras on forest law enforcement, governance and trade in timber products to the European Union? Have criteria and indicators been developed to ensure these changes are checked?

If the Legality Matrices are amended after the entry into force of this Agreement, the following key questions should also be asked:

- 1.12. Were the relevant stakeholders consulted on the amendments of the FLEGT VPA and were their comments and recommendations taken into account?

- 1.13. Is it clear what legal instrument underpins each new element of the Legality Matrices? Are the criteria and indicators to be used to check compliance with each element of the Legality Matrices specified?
- 1.14. Are the criteria and indicators clear, objective and operationally workable?
- 1.15. Have indicators and criteria been developed to ensure these amendments are checked? Do the indicators and criteria clearly identify the roles and responsibilities of the various stakeholders?

## **Section 2: Supply-chain controls**

Systems to check the supply chain must provide credible assurance that timber products can be traced throughout the supply chain from the point of harvesting or legal import to the point of export or sale on the national market. It is not always necessary to maintain physical traceability for a log, log load or timber product from the point of export or sale back to the forest of origin, but it is always necessary between the forest and the first point of mixing (e.g. a timber collection centre, primary and secondary forest product companies, and timber yards).

### **2.1. Harvesting rights**

There is a clear demarcation of areas or estates where forest resource rights have been allocated and the holders of those rights have been identified.

- 2.1.1. Does the control system ensure that only timber from a forest area or estate with valid and authorised harvesting rights enters the supply chain?
- 2.1.2. Does the control system ensure that companies carrying out harvesting operations have been issued appropriate harvesting rights for the forest areas or estates concerned?
- 2.1.3. Have the procedures for issuing harvesting rights and information on issued harvesting rights and their holders been published?

### **2.2. Systems for checking the supply chain**

There are effective mechanisms for tracing timber throughout the supply chain from the point of harvesting to the point of sale on the national and export markets.

The method for identifying timber may vary, ranging from the use of labels for individual items to reliance on documentation accompanying a load or batch. The method chosen should reflect the origin, type and value of timber and the risk of mixing with illegal or unverified timber.

- 2.2.1. Have all the links and operators in the supply chain been identified and described in the control system?
- 2.2.2. Have all the stages in the supply chain been identified and described in the control system?
- 2.2.3. Have methods been established and documented to: (a) identify the origin of the product and (b) prevent mixing with timber from unknown sources in the following stages of the supply chain:
  - timber in the forest,
  - during transport between points of the supply chain,
  - in places of temporary storage,
  - on arrival at primary processing facilities,
  - on arrival at secondary processing facilities,

- on arrival at timber yards or temporary storage places, and
- on arrival at the point of export?

- 2.2.4 Which organisations/bodies are in charge of checking timber flows? Do they have suitable and sufficient human and other resources for carrying out control activities?
- 2.2.5 Is there a protocol for verifying the results of the control procedures that have been set up and applied?
- 2.2.6 Have the supply-chain control procedures been clearly established and communicated to all stakeholders?

### **2.3. Quantities**

There are robust and effective mechanisms for measuring and recording the quantities of timber or timber products at each stage of the supply chain, including reliable and accurate pre-harvest estimates of the volume of standing timber in each felling/harvesting area, estate or unit.

- 2.3.1. Does the control system produce quantitative data on inputs and outputs at the following stages of the supply chain:
- standing timber,
  - sawlogs in the forest,
  - transported and stored timber,
  - timber arriving at the mill/plant,
  - entry into production lines or processing facilities,
  - exit from production lines or processing facilities,
  - exit from the mill/plant,
  - arrival at and exit from local timber yards,
  - arrival at the point of export?
- 2.3.2. Which organisations/bodies are responsible for feeding the quantitative data into the control system? How are these organisations/bodies linked? If different organisations/bodies are responsible, what has been done to ensure that control operations and data management are conducted properly and to the same standard by each organisation?
- 2.3.3. Are the staff of these organisations/bodies given standard training in data management? Do the organisations/bodies have adequate resources in terms of personnel and equipment?
- 2.3.4. How is the quality of the data controlled?

### **2.4. Reconciliation**

All data are recorded in such a way that in due time they can be reconciled with those at prior and subsequent stages of the supply chain.

- 2.4.1. Is reliable reconciliation carried out for the entire supply chain?
- 2.4.2. Are all quantitative data recorded in such a way that in due time quantities can be reconciled with those at prior and subsequent stages in the supply chain?

- 2.4.3. Have methods been developed to assess consistency between inputs of raw materials and outputs of processed products at sawmills and other processing facilities?
- 2.4.4. Is reliable reconciliation of individual items or batches of timber products possible throughout the entire supply chain?
- 2.4.5. What information systems and technologies are applied for storing and reconciling the data, and for reporting? Are robust systems in place for securing the data?
- 2.4.6. Which organisation/body is responsible for data reconciliation? Does it have adequate human and other resources for managing the data?
- 2.4.7. What information on the supply chain controls is published? How can stakeholders have access to this information?
- 2.4.8. Does the control system make for quantitative data reconciliation in accordance with national or international standards, if applicable?

### **2.5. Mixing of legally verified timber with other authorised timber:**

If the mixing of timber from verified legal sources with timber from other sources is allowed,

- 2.5.1. are there sufficient checks in place to exclude material from unknown sources or which was harvested without legal harvesting rights?
- 2.5.2. Does the control system authorise the mixing of verified timber with other authorised timber (e.g. with imported timber or timber originating from a forest area or estate where legal harvesting rights have been granted, but is still not covered by the full verification process)?
- 2.5.3. What control measures are applied in these cases? For example, do checks ensure that the output declared and verified does not exceed the input verified at each stage?

### **2.6. Imported timber products**

There are adequate laws, procedures and controls to ensure that imported timber products have been legally imported.

- 2.6.1. How is the legality of imported timber and timber products demonstrated?
- 2.6.2. What evidence is required to demonstrate that imported products originate from trees harvested legally in a third country?
- 2.6.3. Does the LAS identify imported timber and timber products throughout the supply chain?
- 2.6.4. Where imported timber is used, can the country of origin be identified on the FLEGT licence, including that of components in composite products?
- 2.6.5. Is there some mechanism in place for verifying that importers have carried out the necessary due diligence, including documenting legal origin in the harvesting country, an analysis of the risk of illegal activities and, if necessary, the corresponding mitigation measures?
- 2.6.6. Is the LAS's due diligence and risk analysis approach to evaluating the legality of imported timber working efficiently?
- 2.6.7. How are the organisations in charge of ensuring that only legal timber is imported into Honduras coordinated? Do they have sufficient resources?

## **Section 3: Verification**

Verification provides adequate checks to ensure the legality of the timber. It must be sufficiently robust and effective to ensure that any non-compliance with requirements, whether in the forest or within the supply chain, is identified and corrective action is taken in good time.

### **3.1. Organisation**

Verification is carried out by a government, a third-party organisation or a combination of the two, which has adequate resources, management systems and skilled and trained personnel, and robust and effective mechanisms to control conflicts of interest.

- 3.1.1. Has the Government appointed an organisation or organisations to undertake the verification tasks? Are the terms of reference (including associated responsibilities) clear and publicly available?
- 3.1.2. Does the organisation in charge of verification have adequate resources for carrying out the verification of the legality of the timber and systems for checking the timber supply chain?
- 3.1.3. Does the ICF have adequate resources at all levels for carrying out the verification of the legality of the timber?
- 3.1.4. Do other State institutions involved in the LAS have adequate resources at all levels for carrying out specific aspects of the verification of the legality of timber?
- 3.1.5. Does the organisation in charge of verification have a management system that meets the following requirements:
  - authorisations have been obtained to carry out the necessary on-site inspections to ensure a highly efficient and trustworthy system,
  - adequate resources are available to carry out the necessary on-site inspections to ensure a highly efficient and trustworthy system,
  - all personnel have the necessary training and skills to ensure efficient verification,
  - mechanisms are in place to control conflicts of interest,
  - a transparent system is guaranteed in accordance with the AVA FLEGT,
  - the complaints management system is accessible to the public,
  - a verification methodology has been developed and applied, and
  - the terms of reference of the organisations in charge of verification are clear and made publicly available?

### **3.2. Verification of legality**

The verification method is documented, which ensures that the process is systematic, transparent and evidence-based, and carried out at regular intervals and covers everything included in the Legality Matrices.

3.2.1. Is there a clear definition setting out what has to be verified?

3.2.2. Does the verification methodology cover all elements of the Legality Matrices and include tests of compliance with all specified indicators?

Does verification require:

- checks on documentation, operating records and field operations (also unannounced),
- collection of information by external stakeholders,

- recording of verification activities that allows checking by internal auditors and the independent auditor?
- 3.2.3. Are institutional roles and responsibilities clearly defined and applied?
- 3.2.4. Are the verification results for the Legality Matrices made publicly available? How can stakeholders access this information?

### **3.3 Legal Compliance Certificate**

On the domestic market, operators that comply with all the requirements of the LAS are issued with a Legal Compliance Certificate.

#### **3.3.1. Organisation**

- 3.3.1.1. What body is assigned responsibility to issue Legal Compliance Certificates?
- 3.3.1.2. Are the roles of this body and its personnel with regard to the issuing of Legal Compliance Certificates clearly defined and publicly available?
- 3.3.1.3. Are the competence requirements defined and internal controls established for the personnel of this body?
- 3.3.1.4. Does this body have adequate resources for carrying out its task of issuing Legal Compliance Certificates?

#### **3.3.2. Issuing of Legal Compliance Certificates**

- 3.3.2.1. Does this body have documented procedures for issuing Legal Compliance Certificates? Have these procedures been made public, including any fees payable?
- 3.3.2.2. What evidence is there that these procedures are properly applied in practice?
- 3.3.2.3. Are there adequate records available on issued and rejected Legal Compliance Certificates? Do the records clearly demonstrate the evidence based on which the Legal Compliance Certificates are issued?
- 3.3.2.4. Are the requirements for issuing Legal Compliance Certificates clearly specified and available to operators?
- 3.3.2.5. Which information on Legal Compliance Certificates issued is made publicly available and how often?

### **3.4. Verification of systems for controlling the supply chain**

The scope of what has to be verified is clearly defined and covers the entire supply chain from tree harvesting to the national and export markets. The verification methodology documents the process and ensures that it is systematic and transparent; it is evidence-based and is carried out at regular intervals, covering everything within its scope, such as the regular and timely comparison and reconciliation of data at each stage in the chain.

- 3.4.1. Does the verification methodology fully cover checks on supply chain controls?
- 3.4.2. Is the supply chain clearly set out in the verification methodology?
- 3.4.3. What evidence is there to demonstrate that supply chain controls have actually been verified?
- 3.4.4. Are institutional roles and responsibilities clearly defined and applied? Does the organisation in charge have the personnel and resources needed to carry out supply-chain controls?
- 3.4.5. Are the verification results of supply-chain controls made publicly available? How can stakeholders access this information?
- 3.4.6. Does the LAS's risk [analysis] approach help with effectively controlling timber throughout the supply chain?

- 3.4.7. What IT information system is used to file, verify and record data? Is there a system in place for securing and accessing data?

### **3.5. Recognition of voluntary certification systems**

There are procedures validated by the JIC for recognising voluntary certification systems. These recognition procedures include the LAS's verification based on risk analysis.

- 3.5.1. Are the procedures for recognising voluntary certification systems up to date? Are they accessible to the public?
- 3.5.2. Have any voluntary certification systems been recognised yet? Does the way in which verification systems for imports are recognised help ensure legality?

### **3.6. Cases of non-compliance**

There is an effective and functioning mechanism for requiring and enforcing appropriate corrective action where cases of non-compliance are identified.

- 3.6.1. Does the verification system provide for the above requirement?
- 3.6.2. Has a mechanism been developed for handling cases of non-compliance, with an impact on FLEGT licensing and Legal Compliance Certificates, and is it applied in practice?
- 3.6.3. Is the verification system able to properly identify cases of non-compliance?
- 3.6.4. Are there adequate records available on the cases of non-compliance identified and the corrective measures taken? Is the effectiveness of these corrective measures evaluated?
- 3.6.5. Is information gathered by other stakeholders taken into account to identify and evaluate cases of non-compliance?
- 3.6.6. What information on the cases of non-compliance identified is made public?

### **3.7. Mechanisms for handling complaints**

- 3.7.1. Is there a system for handling complaints and is it available to all stakeholders?
- 3.7.2. Do the verification bodies have mechanisms in place to receive and respond to complaints from stakeholders or the independent auditor?
- 3.7.3. Do the verification bodies have mechanisms in place to receive and respond to infringements/breaches detected by Government officials?
- 3.7.4. Is it clear how complaints are received, recorded, passed on to the next level (where necessary) and responded to?

## **Section 4: FLEGT licences**

Honduras has assigned a licensing authority with overall responsibility for issuing FLEGT licences. FLEGT licences are issued on the basis of either individual consignments or approved operators.

### **4.1. Organisation**

- 4.1.1. What body is assigned responsibility to issue FLEGT licences?
- 4.1.2. Are the roles of the FLEGT licensing authority and its personnel with regard to the issuing of FLEGT licences clearly defined and publicly available?
- 4.1.3. Have the skills requirements for personnel of the FLEGT licensing authority been laid down and have internal controls been established?

4.1.4. Does the FLEGT licensing authority have adequate resources for carrying out its tasks?

#### **4.2. Issuing of FLEGT licences**

4.2.1. Does the licensing authority have documented procedures for issuing the licences? Have these procedures been made public, including any fees payable?

4.2.2. What evidence is there that these procedures are properly applied in practice?

4.2.3. Are there adequate records available on issued and rejected FLEGT licences? Do the records clearly demonstrate the evidence based on which the FLEGT licences are issued?

4.2.4. Are the requirements for issuing FLEGT licences clearly specified and available to exporters?

4.2.5. Which information on FLEGT licences issued is made publicly available and how often?

#### **4.3. FLEGT consignment-based licences**

4.3.1. Is FLEGT licensing based on an individual consignment?

4.3.2. Can the legality of an export consignment be demonstrated through the Government's verification and traceability systems?

#### **4.4. Queries on issued FLEGT licences**

Is there an adequate mechanism for handling queries on FLEGT licences from the competent authorities of Union Member States, as set out in Annex III of this Agreement?

Key questions include:

4.4.1. Can the competent authorities of Union Member States obtain clarification on FLEGT licences issued in Honduras?

4.4.2. Are there clear procedures for communication between the competent authorities of Union Member States and the Honduran FLEGT Licensing Authority?

4.4.3. Are there channels for other national or international stakeholders to enquire about issued FLEGT licences?

### **Section 5: Instructions on the independent auditing of the LAS**

The independent audit of the LAS is a function that is independent of Honduras's forestry sector regulatory bodies. It is designed to provide credibility to the FLEGT licensing scheme by checking that all aspects of the LAS are operating as intended.

#### **5.1. Institutional arrangements**

*Designation of an authority:* Honduras has formally designated an authority to carry out the independent audit of the LAS, which operates effectively and transparently.

*Independence from other LAS functions:* there is a clear separation between the organisations and individuals that are involved in the management or regulation of forest resources and those involved in the independent audit.

5.1.1. Does the Government have documented requirements for the independence of the independent auditor?

5.1.2. Is it stipulated that the organisations or individuals with a commercial interest or an institutional role in the Honduran forest sector may not act as the independent auditor?



*Appointment of the independent auditor:* the organisation acting as the independent auditor has been appointed via a transparent mechanism and there are clear and publicly available rules regarding its activities.

5.1.3. Has the Government made the terms of reference for the organisation acting as the independent auditor of the LAS publicly available?

5.1.4. Has the Government documented the procedures for appointing the organisation acting as the independent auditor of the LAS and made them publicly available?

*Establishing a mechanism for handling complaints:* there is a mechanism for handling complaints and disputes that may arise from the findings independent audit. This mechanism makes it possible to deal with any complaint relating to the operation of the FLEGT licensing scheme.

5.1.5. Is there a documented mechanism for handling complaints that is available to all stakeholders?

5.1.6. Is it clear how complaints are received, documented, passed on to the next level (where necessary) and responded to?

## **5.2. Organisation acting as the independent auditor of the LAS**

*Organisational and technical requirements:* the organisation acting as the independent auditor of the LAS is independent of other parts of the LAS and operates in accordance with a documented management structure and with policies and procedures that are in line with internationally accepted best practices.

5.2.1. Does the organisation acting as the independent auditor of the LAS operate using a documented management system that meets the requirements of ISO 17021 and 17065, or similar standards?

*Monitoring methodology:* the methodology of the independent auditor of the LAS is evidence-based and monitoring is carried out at minimum specified intervals.

5.2.2. Does the methodology of the independent auditor of the LAS specify whether all findings are based on objective evidence with regard to the functioning of the LAS?

5.2.3. Does the methodology of the independent auditor of the LAS specify the maximum intervals at which each element of the LAS will be checked?

*Scope of the independent audit:* the organisation acting as independent auditor has terms of reference that clearly specify what has to be monitored and which cover all agreed requirements for the issuing of FLEGT licences.

5.2.4. Does the methodology of the independent auditor of the LAS cover all elements of the LAS and specify the main tests of its effectiveness?

*Reporting requirements:* Does the organisation acting as the independent auditor report regularly to the JIC on the integrity of the LAS, including any cases of non-compliance, and on its assessment of corrective measures taken to address them?

5.2.5. Do the terms of reference of the organisation acting as the independent auditor of the LAS specify the reporting requirements and reporting intervals?

## **Annex VIII**

### **Supplementary and support measures**

#### **INTRODUCTION**

Effective implementation of this Agreement in Honduras requires the establishment of supplementary and support measures for institutions and actors responsible for compliance with this Agreement.

The supplementary and support measures are the result of consultations with institutions involved in the process, the findings and recommendations of the field testing carried out during the process of negotiation of this Agreement, and the recommendations of various studies concerning the forest sector in Honduras. Actions not identified during the negotiations will be included in the work plans of the Technical Secretariat and the Interinstitutional Secretariat for VPA Implementation (SIIAVA) as supplementary or additional support measures.

Following the entry into force of this Agreement, Honduras will start on the work plan to carry out these measures, including an induction process for the current and new authorities of the institutions involved; this process will help ensure a speedy and effective transition by transferring the knowledge and the experience gained during the negotiations for this Agreement.

For planning purposes supplementary and support measures have been grouped into five categories:

- Stepping-up coordination between public institutions and other actors linked to this Agreement
- Capacity-building
- Strategic action
- Studies
- Legal instruments.

There are three levels of priority for the implementation of supplementary and support measures:

- High = measures indispensable for the start-up of the Honduran LAS.
- Medium = useful measures for optimising the functioning of the LAS or measures to ensure that a good proportion of operators are able to comply with legal requirements and the LAS.
- Low = more general sector-support measures (institutional, private sector, civil society, etc.).

A Supplementary and Support Measures Handbook will describe the focus and scope of the measures listed in this Annex, under the responsibility of the JIC, which will review and update the Manual if necessary.

## **1. STEPPING UP COORDINATION BETWEEN PUBLIC INSTITUTIONS AND OTHER ACTORS LINKED TO THIS AGREEMENT**

### **1.1 Conclude and implement interinstitutional cooperation agreements for this Agreement**

In order to establish institutional agreements on the composition of the SIIAVA and the JIC and on implementation of this Agreement, a memorandum of understanding will be concluded between public-sector institutions, including: the Ministry of Energy, Natural Resources, Environment and Mines (MiAmbiente), the Forest Conservation Institute (ICF), the Institute of Property (IP), the National Agrarian Institute (INA), the Revenue Administration Service (SAR), the Customs Revenue Subdirectorate (DARA), the Association of Honduran Municipalities (AMHON), the Honduran Social Security Institute, (IHSS), the Ministry of Labour and Social Security (STSS), the Ministry of Agriculture and Livestock (SAG), the National Directorate of Indigenous and Afro-Honduran Peoples (DINAFROH), the Institute for Access to Public Information (IAIP), the Public Prosecutor's Office (MP), the Security Ministry (SSN, representing the National Preventive Police (PNP)), the National Defence Ministry (SEDENA, representing the armed forces of Honduras (FFAA)), the Attorney-General's Office (PGR), the Central Bank of Honduras (BCH), the National School of Forest Sciences (ESNACIFOR) and other academic institutions concerned with environmental and forestry issues. Furthermore, cooperation agreements will be established where deemed useful for coordination between various institutions involved in this Agreement.

### **1.2 Make the relevant organisational adjustments in public institutions linked to this Agreement and provision in their budgets for the financing necessary to implement this Agreement**

Each institution will refer to the text and annexes of this Agreement, in particular this Annex, taking them as a guide for the budget adjustments required. The Ministry of Finance (SEFIN) will take the necessary steps to ensure coverage of the related budgetary requirements of this Agreement requested by MiAmbiente, ICF, IP, INA, SAR, DARA, AMHON, IHSS, STSS, SAG, DINAFROH, IAIP, MP, SSN, SEDENA, PGR, BCH, ESNACIFOR and other academic institutions concerned with environmental and forestry issues. These resources will be used to implement the-related activities of this Agreement and will be included in the updated institutional strategic plans and annual operating plans starting from the six-month period following the date of entry into force of this Agreement.

### **1.3 Develop and implement strategies for interinstitutional coordination to ensure fulfilment of the indicators specified in the Legality Matrices and the LAS requirements coming under the responsibility of each institution**

The implementation of the LAS in general and the operation of the ICF's Legality Verification Unit in particular require close coordination between the ICF and institutions related to this Agreement to standardise the flow of information to that Unit. Strategic actions to be implemented will be coordinated through the Interinstitutional Secretariat for the Implementation of the FLEGT VPA (SIIAVA).

#### **1.4 Establish mechanisms for exchanging information between institutions involved in the LAS, prioritising the intercommunication of IT systems**

Information exchanges will increase the flow of data between the systems of the institutions responsible for implementing the LAS and monitoring legality indicators. A database will be set up to make data available to the Legality Verification Unit to be established within the ICF. The measure will enable data interaction between SIRMA, SNIF, Geoportal (of the ICF) and the systems of other institutions, and with existing systems of professional associations.

A computer system with features tailored to the implementation capacity of individual institutions will be developed. Depending on the results of the diagnostics and feasibility analysis of the exchange system, it may be possible to consider non-computerised solutions for some components of the system.

#### **1.5 Implement the Action Plan for the National Strategy Against Illegal Logging (ENCTI)**

This is a crosscutting strategy for the implementation of this Agreement because it includes activities related to several principles of the Legality Matrices, as described in Section 11 of Annex V. The ICF has made a number of attempts to implement the ENCTI, but without success, mainly owing to a lack of financial resources. In 2017 the implementation of a few prevention and monitoring actions was planned and budgeted for as an initial step towards a steady build-up of actions and of the resources that the relevant institutions can use to implement the ENCTI.

#### **1.6 Create and implement a methodology for monitoring and evaluating progress in implementing this Agreement**

In order to monitor and evaluate progress in implementing this Agreement each institution needs a baseline and an established methodology to enable it to systematically monitor progress made in implementing this Agreement, something that will also be used as a guide for the annual report on this Agreement and its biannual review by the Parties.

#### **1.7 Create and implement a methodology for measuring the impact of this Agreement**

To measure the impact of this Agreement, particularly on vulnerable groups, a baseline and an established methodology for the various actors are needed to systematically measure the impact of this Agreement, as laid down in Article 19(3)(h) and in Article 17.

#### **1.8 Implement a specific legalisation plan for national forest areas and indigenous territories**

A special plan will be drawn up and implemented with the aim of executing existing agreements between the ICF, IP and INA.

#### **1.9 Strengthen capacity for coordination with the judicial officers and with the law enforcement authorities on cases relating to the forestry sector**

This measure is designed to build capacity, particularly training for judges and magistrates on specific issues related to the implementation of environmental and forestry laws, with an eye to their role in effective implementation of this Agreement.

#### **1.10 Coordinate the drafting of the legislation required for implementation of the LAS complaint procedures**

This measure lays down the interaction, functioning and competence of each body described in Section 10 of Annex V dealing with LAS complaint procedures, whether existing or to be developed. These bodies include all institutions involved in the LAS, the independent audit authority, the Joint Implementation Committee and civil society.

#### **1.11 Strengthen and put on official footing public participation aimed at improving forest governance**

The ICF will sign agreements on capacity building and interinstitutional coordination with civil society organisations and with organisations of the Indigenous and Afro-descendant Peoples of Honduras (PIAH) for the independent monitoring of the functioning of the LAS for timber products. This will involve oversight of forestry and industrial operations by local people.

#### **1.12 Create and implement a public information management system**

A database will be developed for consultation, containing information of public interest described in Annex IX, as well as other relevant information that may be generated.

## **2. CAPACITY BUILDING**

### **2.1 Develop and implement a capacity-building programme for institutions involved in the implementation of this Agreement**

The ICF and institutions involved in the implementation of this Agreement will develop and implement a training programme adapted to the responsibilities of each institution with the aim of improving their knowledge.

### **2.2 Develop and implement a capacity-building plan for operators in the forestry sector**

The field testing carried out during the negotiations for this Agreement in October 2016 highlighted the weaknesses and loopholes in the legal compliance of forest operators such as forest owners, forest product companies, agro-forestry groups, SMEs and microenterprises. The study provided for in measure 4.4 will serve as the basis for designing training courses for operators in the forestry sector. This plan includes technical training for operators, prioritising SMEs and microenterprises and taking account of their specific needs.

## **3. STRATEGIC ACTIONS**

### **3.1 Streamline and simplify procedures for the activities of government institutions concerning the forest sector**

This requires a detailed review of current administrative procedures governing the forest supply chain. The aim of this measure is to make investment in the forestry sector attractive and to make life easier for SMEs and microenterprises by speeding up VPA formalities in all institutions.

### **3.2 Evaluate and update the procedures in institutions involved in the implementation of this Agreement for handling infringements and imposing penalties**

This measure will review the regulations and procedures for offences and penalties applied in each of the institutions involved in the implementation of this Agreement. This measure will be coordinated by the SIIAVA.

### **3.3 Establish and implement a risk-based checking and verification procedure**

To reduce unlawful practices - the main challenge to implementing the LAS - a comprehensive risk-management mechanism has to be implemented across the supply chain in the interests of timely and effective verification, as laid down in Section 6.2.5 of Annex V.

### **3.4 Update, maintain and implement the National Timber Traceability IT System (SIRMA)**

SIRMA records the documentation on harvesting, checking, monitoring and verification operations; this ensures traceability in the forest supply chain.

This measure is linked to measure 3.5 involving interaction between the SNIF and SIRMA on information management.

### **3.5 Create and implement new modules in the National Forestry Information System (SNIF)**

This measure will enable interaction between SIRMA and the SNIF through a web connection to generate volume control reports for all harvesting licences, which must be authorised by the documentary check carried out using the SNIF. In addition, SIRMA currently manages a lot of information on certain harvesting licences that are not in the SNIF, which means that modules to connect the systems will be required.

### **3.6 Draw up and implement policies to decentralise and devolve administrative procedures relating to the forestry sector in government institutions**

The aim of this measure is to develop and implement a strategy to devolve and so speed up procedures in institutions concerned by the indicators in the Legality Matrices. A

further aim is to create and implement a decentralisation strategy that will progressively transfer administrative powers from the ICF to the municipalities together with the resources and capacity to shoulder them.

### **3.7 Create safeguards, in the implementation of this Agreement, for vulnerable groups**

These are targeted actions to protect the rights of vulnerable groups. The implementation of the methodology of monitoring, evaluation and impact on the implementation of this Agreement (supplementary measure 1.7) will identify additional safeguards to those specified in Annex V (Section 12).

### **3.8 Develop and implement a phased strategy to reinforce legal compliance by micro-, small and medium-sized enterprises in the forestry sector**

To draw up this strategy, supplementary measure 4.6 (census of operators) should be developed, underpinned by supplementary measures 2.2 (capacity-building), 3.1 (speeding up administrative procedures) and 3.12 (incentives).

### **3.9 Design and implement a national system of land-use classification**

The national system of classification will classify and monitor land use over time, including forested land, scattered trees outside forests, and other types of soil coverage. The classification criteria will include the economic and social dimensions of land use as well as its biophysical aspects. The system will be designed by reference to existing or planned technical-scientific studies, as provided for in the Law on Forestry, Protected Areas and Wildlife.

The national classification system will be headed by the ICF, which will be responsible for its design, planning and implementation, supported by MiAmbiente, SAG, Secretariat for Human Rights, Justice, Governance and Decentralisation and INA under their competence. The design of the system will include specific measures to ensure that the necessary capacity to administer and maintain it is retained over time and that the datasets produced are accessible and up to date.

### **3.10 Update MiAmbiente's environmental categorisation table for the Environmental Licence Certificate for forestry companies and timber yards**

The aim of this measure is to update the environmental impact categories for the activities of forestry companies and timber yards through interinstitutional coordination between the ICF and MiAmbiente; these categories will be published and officially adopted with a view to their implementation. A module will be created to issue certificates exempting projects with a low environmental impact from the Environmental Licence Certificate, as will a module in the Simplified Environmental Licensing System (SLAS) to reduce the time needed to obtain an exemption from the Environmental Licence Certificate for projects not covered by the Environmental Classification Table.

### **3.11 Establish a system in the Ministry of Labour and Social Security for recording and managing information on employment in the forestry sector**

In order to assess legal compliance with the indicators for employment contracts, payment of the minimum wage and health and safety measures (indicators for Principle 4 in the Legality Matrices), the STSS's current capacity will need boosting with the setting-up of an IT system to register domestic forestry operators and carry out the necessary follow-up, taking into account the simplification of formalities.

The setting-up of the IT system for recording and managing information may be done gradually, depending on the capacity of the STSS departments involved and of the forestry operators at the national level, creating an interconnection with other institutions (including the IHSS).

### **3.12 Design and implement an incentive-based strategy focusing on micro-, small and medium-sized enterprises in the forestry sector**

The aim of this measure is to implement Articles 35 and 149 of the Forestry Law as regards incentives, seeking ways of using the available resources and making them available to beneficiaries engaged in forestry activities, especially micro-, small and medium-sized enterprises in the forestry sector. These incentives will also cover forest owners.

### **3.13 Design and implement a National Communication Strategy for this Agreement**

This National Communication Strategy will serve to disseminate the scope of this Agreement and raise awareness of legal compliance among forestry sector operators. The Strategy will be implemented in stages, starting with employment and social aspects.

### **3.14 Agree on policies aimed at improving and harmonising the agricultural and forestry sectors**

With the implementation of this measure, policies relevant to the agricultural, forestry and land-use planning sectors, *inter alia*, will be reviewed with the aim of reducing the conversion of forest land for agriculture and strengthening checks on the legality of conversions. The ICF, MiAmbiente, SAG and the *Secretaría de Desarrollo Económico* (SDE), among other bodies, will play a leading role in this process.

## **4. STUDIES**

The ICF or the relevant institution identified in the list of supplementary measures at the end of this Annex, in coordination with other institutions and ranking each in order of priority, will carry out the following studies:

### **4.1 Analyse institutional technical and operational capacities for the implementation of this Agreement**

The result of this analysis will be used to develop supplementary measures 1.2 and 2.1, as it will provide the information needed as guidance for institutional capacity-building.



#### **4.2 Study the impact of this Agreement on the livelihoods of vulnerable groups, including the creation of a baseline**

The term 'vulnerable groups' covers the Indigenous and Afro-descendant Peoples of Honduras (PIAH), agroforestry organisations and small carpentry workshops, among others. The outcome of this study will be used to develop supplementary measure 3.7.

#### **4.3 Review the customs procedure related to the level of legality verification (imports and exports) in order to harmonise it with procedures of this Agreement**

This study will review the customs procedure related to the level of legality verification for timber imports and exports, so that the procedure can be updated if necessary.

#### **4.4 Carry out a baseline study on the level of compliance of forestry sector operators, including the environmental, social and economic aspects covered by the principles, criteria and indicators of this Agreement**

This study will make it easier to implement control and verification mechanisms, and to design operator capacity-building programmes.

#### **4.5 Study performance in primary and secondary industry processing as a basis for establishing controls in traceability systems**

These studies will provide the ICF with data on primary wood-processing performance and will be used to implement controls on forestry companies.

#### **4.6 Update the census of primary and secondary forestry companies and timber yards in order to implement control and verification mechanisms**

For the purposes of this supplementary measure, and in accordance with the descriptions in the Forestry Law, small joinery, carpentry and similar workshops form part of secondary industry.

### **5. LEGAL INSTRUMENTS**

The ICF or the relevant institution identified in the list of supplementary measures, in coordination with other institutions involved in implementing this Agreement, will:

#### **5.1 Create and institutionalise the SIIAVA, through a legal instrument**

#### **5.2 Create and implement a legal instrument for due diligence in the national timber product market**

**5.3 Create and implement a legal instrument for due diligence in imports of timber products**

**5.4 Assess, update and implement the rules on control mechanisms for timber and timber products in transit and timber and timber products imported into the country**

**5.5 Create and implement a regulation to define the procedures for issuing legality certificates and FLEGT and H-Legal licences**

**5.6 Create and implement rules for the harvesting of scattered trees outside forests**

These rules will establish technical and legal mechanisms through which an owner of scattered trees may or may not harvest them. It is envisaged that the volumes of timber obtained from the harvesting of these trees will be supplied as a priority to small forestry companies (carpentry workshops). However, the rules will cover all types of operators that may use this type of timber, whatever the size of the company.

**5.7 Create and implement rules for tree harvesting under non-commercial licences**

These rules will establish technical and legal mechanisms through which the interested party (who may or may not be the landowner) can harvest scattered trees for their own use. The products obtained through these non-commercial licences will not enter the supply chain. However, they will be registered and monitored by the ICF.

**5.8 Develop and implement a regulation and other arrangements for implementing FPIC**

Once the Law on Free Prior and Informed Consent (FPIC) is legally binding in the country, the mechanisms to implement it will need to be created.

To this end, the State of Honduras undertakes as far as is possible, at all levels and in all bodies, and within the scope of its powers, to support the process of creating and developing the relevant regulation, ensuring the involvement of the Indigenous and Afro-descendant Peoples and communities of Honduras.

An FPIC implementation protocol will also be developed in accordance with international standards, to be applied in the forestry sector until that Law has been adopted.

**5.9 Create and implement a regulation to lay down the procedures for categorising infringements or non-compliances by public officials**

**5.10 Draft and implement guidelines on the treatment of infringements and the imposition of penalties on forestry sector operators**

**5.11 Create and implement the regulatory framework for contractors' operations**

**5.12 Review, update and implement the guidelines and standards for better forest management**

In updating the guidelines and standards, greater focus will be placed on broadleaf forests, since pine forests already have rules governing their exploitation.

**5.13 Update and implement the rules for certified forest plantations**

**5.14 Create and implement instructions to check the compliance of the protection programme with approved Annual Operating Plans**

**5.15 Create and implement an instrument defining the role of Municipal Environmental Units (UMAs) in issuing Environmental Licence Certificates in coordination with MiAmbiente and the AMHON**

**5.16 Assess, update and implement the rules for special plans for agroforestry systems (PESAs), taking into account surface areas greater than 100 hectares**

**5.17 Develop and implement a mechanism for the ICF to recognise private forest certification schemes**

**6. Funding mechanisms for supplementary and support measures**

The Parties have determined that, in order to implement most of the measures referred to in this Annex, and other actions required to implement this Agreement, additional technical and financial resources are needed. These resources will ensure that the institutions clearly identified in the legality verification can implement actions with the assurance of adequate resources, management systems and skilled staff, and robust and efficient mechanisms for the effective implementation of this Agreement, and enable the root causes and drivers of illegal logging to be addressed. The provision of additional resources will be subject to the normal procedures for programming assistance to Honduras and to the budgetary procedures of Honduras itself.

This means that some of the supplementary and support measures referred to in this Annex may be financed through:

- Own funds of the Government of Honduras:
  - General State Budget.
- Contributions from the European Commission and/or Member States of the Union:
  - Projects
  - Budget support, where appropriate.

- Other sources of funding.

The Parties have decided that, if additional financial resources are needed, they will undertake to seek other sources of additional funding. In this context, the Parties will ensure that activities associated with the implementation of this Agreement are coordinated with existing and future development initiatives, in particular REDD+.

## SUPPORT AND SUPPLEMENTARY MEASURES BY STRATEGIC AREA

No	Priority	Category	Action/Activity	Institution responsible
1.1	High	Strengthening coordination	Conclude and implement interinstitutional cooperation agreements in the framework of this Agreement.	ICF, SIIAVA
1.2	High	Strengthening coordination	Make the relevant organisational adjustments in public institutions linked to this Agreement and provision in their budgets for the financing necessary to implement this Agreement.	SEFIN, SIIAVA
1.3	High	Strengthening coordination	Develop and implement strategies for interinstitutional coordination to ensure fulfilment of the indicators specified in the Legality Matrices and the LAS requirements coming under the responsibility of each institution.	SIIAVA
1.4	High	Strengthening coordination	Establish mechanisms for exchanging information between institutions involved in the LAS, prioritising the intercommunication of IT systems.	SIIAVA
1.5	High	Strengthening coordination	Implement the Action Plan for the National Strategy Against Illegal Logging (ENCTI).	ICF, FFAAH, FEMA, PGR, PNP, FTIA, FUSINA.
1.6	High	Strengthening coordination	Create and implement a methodology for monitoring and evaluating progress in implementing this Agreement.	ICF, SIIAVA
1.7	High	Strengthening coordination	Create and implement a methodology for measuring the impact of this Agreement.	ICF, SIIAVA
1.8	High	Strengthening coordination	Implement a specific legalisation plan for national forest areas and indigenous territories.	ICF, INA, IP, AMHON
1.9	High	Strengthening coordination	Strengthen capacity for coordination with the judicial officers and with the law enforcement authorities on cases relating to the forestry sector.	ICF, FEMA, PGR, Supreme Court
1.10	High	Strengthening coordination	Coordinate the drafting of the legislation required for implementation of the LAS complaint procedures.	ICF, SIIAVA
1.11	High	Strengthening coordination	Strengthen and put on official footing public participation aimed at improving forest governance.	ICF
1.12	Medium	Strengthening coordination	Create and implement a public information management system.	SIIAVA

No	Priority	Category	Action/Activity	Institution responsible
2.1	High	Capacity-building	Develop and implement a capacity-building programme for institutions involved in the implementation of this Agreement.	ICF, SIIAVA, ESNACIFOR and other academic institutions.
2.2	Medium	Capacity-building	Develop and implement a capacity-building plan for operators in the forestry sector.	ICF
3.1	High	Strategic action	Streamline and simplify procedures for the activities of government institutions concerning the forest sector.	ICF, SAR, SAG, IHSS, STSS
3.2	High	Strategic action	Evaluate and update the procedures in institutions involved in the implementation of this Agreement for handling infringements and imposing penalties.	SIIAVA
3.3	High	Strategic action	Establish and implement a risk-based checking and verification procedure.	ICF, MiAmbiente, PNP, MP
3.4	High	Strategic action	Update, maintain and implement the National Timber Traceability IT System (SIRMA).	ICF
3.5	High	Strategic action	Create and implement new modules in the National Forestry Information System (SNIF).	ICF
3.6	Medium	Strategic action	Draw up and implement policies to decentralise and devolve administrative procedures relating to the forestry sector in government institutions.	ICF, SAR, SAG, IHSS, STSS
3.7	Medium	Strategic action	Create safeguards, in the implementation of this Agreement, for vulnerable groups.	SIIAVA
3.8	Medium	Strategic action	Develop and implement a phased strategy to reinforce legal compliance by micro-, small and medium-sized enterprises in the forestry sector.	SIIAVA
3.9	Medium	Strategic action	Design and implement a national system of land-use classification.	IP, ICF, INA
3.10	Medium	Strategic action	Update MiAmbiente's environmental categorisation table for the Environmental Licence Certificate for forestry companies and timber yards.	ICF, MiAmbiente
3.11	Medium	Strategic action	Establish a system in the Ministry of Labour and Social Security for recording and managing information on employment in the forestry sector.	STSS
3.12	Low	Strategic action	Design and implement an incentive-based strategy focusing on micro-, small and medium-sized enterprises in the forestry sector.	ICF, SAR, SAG, IHSS, STSS

No	Priority	Category	Action/Activity	Institution responsible
3.13	Low	Strategic action	Design and implement a National Communication Strategy for this Agreement.	ICF, SIIAVA
3.14	Low	Strategic action	Agree on policies aimed at improving and harmonising the agricultural and forestry sectors.	SDE, ICF, SAG, MiAmbiente, IHCAFE
4.1	High	Studies	Analyse institutional technical and operational capacities for the implementation of this Agreement.	SIIAVA
4.2	High	Studies	Study the impact of this Agreement on the livelihoods of vulnerable groups, including the creation of a baseline.	SEDIS-DINAFROH (Secretariat for Social Inclusion), ICF
4.3	High	Studies	Review the customs procedure related to the level of legality verification (imports and exports) in order to harmonise it with procedures of this Agreement.	DARA, SAR, ICF
4.4	High	Studies	Carry out a baseline study on the level of compliance of forestry sector operators, including the environmental, social and economic aspects covered by the principles, criteria and indicators of this Agreement.	ICF, SIIAVA
4.5	Medium	Studies	Study performance in primary and secondary industry processing as a basis for establishing controls in traceability systems.	ICF, AMADHO, ESNACIFOR and other academic institutions.
4.6	Medium	Studies	Update the census of primary and secondary forestry companies and timber yards in order to implement control and verification mechanisms.	ICF
5.1	High	Legal instruments	Create and institutionalise the SIIAVA.	SDE, ICF, IP, INA, DINAFROH, MiAmbiente, SAG, SAR, DARA, IAIP, Police, FFAA, PGR, IHSS, STSS, ESNACIFOR and other academic institutions.
5.2	High	Legal instruments	Create and implement a legal instrument for due diligence in the national timber product market Create and implement a.	ICF, PGR, MP
5.3	High	Legal instruments	legal instrument for due diligence in imports of timber products.	ICF, DARA, BCH

No	Priority	Category	Action/Activity	Institution responsible
5.4	High	Legal instruments	Assess, update and implement the rules on control mechanisms for timber and timber products in transit and timber and timber products imported into the country.	DARA, ICF, SAR
5.5	High	Legal instruments	Create and implement a regulation to define the procedures for issuing legality certificates and FLEGT and H-Legal licences.	ICF
5.6	High	Legal instruments	Create and implement rules for the harvesting of scattered trees outside forests.	ICF
5.7	High	Legal instruments	Create and implement rules for tree harvesting under non-commercial licences.	ICF
5.8	High	Legal instruments	Develop and implement a regulation and other arrangements for implementing FPIC.	STSS, DINAFROH, CONPAH, indigenous associations and other concerned organisations
5.9	Medium	Legal instruments	Create and implement a regulation to lay down the procedures for categorising infringements or non-compliances by public officials.	SIIAVA
5.10	Medium	Legal instruments	Draft and implement guidelines on the treatment of infringements and the imposition of penalties on forestry sector operators.	ICF, SIIAVA
5.11	Medium	Legal instruments	Create and implement the regulatory framework for contractors' operations.	ICF
5.12	Medium	Legal instruments	Review, update and implement the guidelines and standards for better forest management.	ICF
5.13	Medium	Legal instruments	Update and implement the rules for certified forest plantations.	ICF
5.14	Low	Legal instruments	Create and implement instructions to check the compliance of the protection programme with approved Annual Operating Plans.	ICF
5.15	Low	Legal instruments	Create and implement an instrument defining the role of Municipal Environmental Units (UMAs) in issuing Environmental Licence Certificates in coordination with MiAmbiente and the AMHON.	MiAmbiente, AMHON
5.16	Low	Legal instruments	Assess, update and implement the rules for special plans for agroforestry systems (PESAs), taking into account surface areas greater than 100 hecta.	ICF



No	Priority	Category	Action/Activity	Institution responsible
5.17	Low	Legal instruments	Develop and implement a mechanism for the ICF to recognise private forest certification schemes.	ICF

## **Annex IX**

### **Transparency and access to public information**

#### **1. INTRODUCTION**

In order to implement this Agreement, amongst other things, information has to be made available on the FLEGT VPA and its objectives, implementation, monitoring and control. This information has to be published by the Joint Implementation Committee (JIC) and by each of the Parties in order to guarantee that all stakeholders understand the FLEGT licensing scheme and good governance is provided with respect to forestry management.

To meet this objective, this Annex sets out (i) the forestry-related information to be made available to the public, (ii) the bodies responsible for making that information available and (iii) the mechanisms for accessing it.

Implementing measures to make the information available ensure that: 1) the actions of the JIC and other institutions and bodies involved when implementing this Agreement are transparent, comprehensible and appropriate for all stakeholders in the forest-products supply chain and the general public; 2) there is a mechanism in place so that stakeholders can freely access key information on the forestry sector; 3) the functioning of the Honduran Legality Assurance System (LAS) for timber products is strengthened through the availability of information for independent monitoring, and 4) the overall objectives of this Agreement are achieved.

The provisions of this Agreement comply with Honduran legislation on access to public information ensuring that this information is available, disseminated on a regular basis and provided immediately upon request. In addition, this Annex is underpinned by the laws, regulations and agreements referred to in Annex II, and those referred to in Annex V.

The transparency mechanism gives stakeholders access to relevant information when monitoring the implementation of the Agreement and to key information on the forestry sector in order to strengthen the governance of this sector in Honduras.

#### **2. OBJECTIVES**

- To strengthen the credibility and governance of the national forestry management system and the FLEGT licensing scheme,
- to increase awareness of the information that Honduras makes public,
- to ensure that information on the forestry sector is disseminated, and
- to enable stakeholders to monitor the implementation of this Agreement.

#### **3. BACKGROUND**

The provisions of this Annex comply with the Law on Transparency and Access to Public Information (the LTAIP) passed by the National Congress of Honduras on 30 December 2006. This Law aims to develop and implement the national policy of transparency, and to guarantee every person the right to access public information with a view to strengthening the rule of law and consolidating democracy through citizen participation.

Article 6 of the LTAIP refers to the promotion of a culture of transparency and public access to information, stating that ‘the institutions covered by this Law shall give public servants regular and up-to-date training in providing access to information in a culture of transparency, both for information and public governance...’

To comply with the LTAIP, all public institutions in Honduras have a ‘Transparency Portal’ that provides the general public with information on the institution, its functions, powers, activities and resource management. In addition, every institution has a Public Information Officer responsible for answering queries from and providing information to citizens upon request, as long as it has not been marked confidential. The information requested may be given in person, faxed, sent by post or e-mailed.

Article 17 of the LTAIP stipulates that ‘public information is considered confidential if the harm the information could cause is greater than the public interest of being aware of it, or if disclosing the information would put at risk or adversely affect:

- 1) national security;
- 2) the life, safety and health of any individual, humanitarian aid, the legally protected interests of children or other persons, or the guarantee of habeas data;
- 3) the progress of confidential investigations in connection with the prevention, investigation and prosecution of crimes or the delivery of justice;
- 4) the interests protected by the national Constitution and laws;
- 5) the conduct of international negotiations and relations, and
- 6) the economic, financial or monetary stability of Honduras or its governance.’

To strengthen governance in the forestry sector, the National Institute for Forest Conservation and Development, Protected Areas and Wildlife (ICF) has a communications strategy that will direct communications regarding this Agreement in Honduras.

This communication strategy is in the form of guidelines that aim to improve communications and so make Honduras’ work in forest management more visible to national and international audiences. It includes suggestions for increasing synergies for work between several stakeholders (the private sector, civil society and the Indigenous and Afro-descendant Peoples of Honduras) so that, through strategic and coordinated communications, existing and emerging avenues of communication can be built upon.

If there is more public understanding of Honduras’ work in supporting this Agreement and of the social benefits of strengthening forest management, it will encourage the public to actively take part in promoting good governance and will add to the credibility of public institutions.

## 4. INFORMATION TO BE PUBLISHED

### 4.1. Information that will be published by the JIC

- a. Structure and functioning of the JIC.
- b. Minutes of meetings of the JIC and decisions taken.
- c. Annual Report of the JIC containing in particular the following information:
  - progress made in achieving the objectives of this Agreement within the specified deadline, and all matters relating to its implementation;
  - the quantities of timber and timber products imported into Honduras and the measures taken by the Parties to prevent the import of timber and timber products of illegal origin in order to maintain the integrity of the FLEGT licensing scheme;
  - cases of non-compliance with the FLEGT licensing scheme in Honduras and measures taken to address such cases, including rejecting FLEGT licence applications;
  - number of cases, and quantities of timber and timber products involved, which have arrived at Union customs points without a FLEGT licence;
  - actions to prevent the export of timber and timber products of illegal origin to non-Union markets or sale thereof on the national market;
  - a list of FLEGT licences issued by Honduras;
  - quantities of timber products imported by the Union under the FLEGT licensing scheme, according to the relevant Harmonised System (HS) headings and the Union Member State in which import into the Union took place.
- d. General information on the independent audit, including:
  - terms of reference for the independent audit;
  - announcement of the audit;
  - terms of reference and inspection and audit reports from the independent auditor;
  - complaints about the auditor and the independent audit and how they are handled.
- e. Guidelines for the verification of legality, as set out in Annex II.
- f. The schedule for implementation of this Agreement, and a summary of activities carried out, with an assessment of the progress made in its implementation, which includes information on the progress made in the implementation of the supplementary measures set out in Annex VIII.

### 4.2. Information on the implementation and performance of this Agreement

- The text of this Agreement, its Annexes and any amendments.

#### 4.2.1. Information on LAS

- Documentation on the Honduran LAS for timber products,
- guidelines for the verification of legality, as set out in Annex II, and
- procedures for issuing FLEGT licences.

#### 4.2.2. Information on structures and procedures for this Agreement

- List of institutions/organisations involved in this Agreement,
- structure and functioning of the Legality Verification Unit, and
- structure and functioning of the FLEGT Licensing Unit.

#### 4.2.3. Documentation linked to this Agreement

- National Strategy Against Illegal Logging (ENCTI),
- communications strategy for the FLEGT VPA and improving governance in the forestry sector, and
- special plan to legalise land ownership.

#### 4.3. Geographical Information

- Political-administrative divisions,
- vegetation cover,
- protected areas,
- declared microbasins,
- approved Forest Management Plans for land that is privately, nationally or municipally (ejido area) owned,
- areas recorded in the Catalogue of Inalienable Public Forest Resources, and
- title deeds registered in the name of the ICF and registered titles of territories of the Indigenous and Afro-descendant Peoples of Honduras.

#### 4.4. Information on forest management and harvesting

- Management Plans approved over the year,
- Annual Operating Plans approved over the year,
- Rescue Plans approved over the year,
- Special Agroforestry System Plans approved over the year,
- Plantation certificates issued over the year,
- harvesting of certified forestry plantations approved over the year,
- harvesting of national forests through tenders (if applicable),
- management contracts for communities, organised groups and legal or natural persons,
- forest product companies and timber yards registered with the ICF, and
- quantities of products and by-products harvested annually by type of authorisation, forest, land tenure and forestry region.

#### 4.5. Information on timber production

- Annual production of processed timber products by type of forest, forestry region and forest product company.

#### 4.6. Information on international trade

- Import/export register for timber products including: quantities, types of product and trading countries,
- published domestic prices for timber, and
- CITES certificates issued.

#### 4.7. Revenues from administrative charges

The collection of these revenues is governed by Article 503 of the General Forestry Regulation by means of forms and payments sent to the Honduran National Treasury. Under the powers conferred on it by law and in fulfilment of the tasks and functions assigned to it in the Law on Forestry, amongst others, the ICF will publish these revenues regularly and routinely using electronic or computerised means, or in print form if necessary (Article 13 of the LTAIP).

- a. Report on revenues from administrative charges applied by the ICF  
With regard to forest harvesting and the payment of charges, fees and taxes, it was decided to include the following for publication:
  - 1) Payments to the ICF for administrative costs incurred when approving and monitoring Management Plans and Annual Operating Plans for privately-owned and municipal (ejido) forests (Article 507 of the General Forestry Regulation). The charges payable from the date of entry into force of this Agreement are laid down in Resolution GG-486-1996 (pine timber) and Resolution GG-MP- 104-2007 (broadleaved timber) and may be modified. If modifications are made to these service charges, the modifications will be published in new resolutions.
  - 2) A logging fee is paid to the ICF for harvesting pine or broadleaved timber in nationally-owned forests, as laid down in Agreement No 033-2015 issued by the ICF and may be modified. Any changes made to any resolution will be published.
- b. Reports on other revenues
  - 1) Payments of fines and sanctions for crimes and offences laid down in the Law on Forestry and its Implementing Regulation. With regard to forestry offences, the ICF sets and administrates the fines and sanctions, as laid down in the Special Regulation on the Application of Fines and Sanctions by the Administrative Offences Commission (ICF Agreement No 010-2014).

#### 4.8. Forestry crimes and offences

Information on all cases of forestry crimes brought before the Courts and for which there has been a final ruling.

## 5. DISSEMINATION MECHANISMS

The Parties undertake to ensure transparency in all actions taken within the scope of this Agreement. With this in mind, in the event of a specific request made by another stakeholder in this sector, they will make available all information they consider necessary.

The methods and channels used to publish the information in question must include the following:

*Official reports and printed media,*

- Information on the Honduran forestry sector is published in the Annual Forestry Statistics (ICF); this informs the general public about what is happening in the forestry sector. In addition, alliances will be encouraged with different stakeholders in the forestry sector for investing in printed media (newsletters, leaflets, banners, etc.) and publishing up-to-date information. The Union publishes FLEGT voluntary partnership agreements in its Official Journal. Each country's annual report on the FLEGT VPA is another source of information in print on these agreements.

*Internet sites*

- The ICF will set up a page on its website, which will include links to all institutions and organisations involved in this Agreement. Geographical information on the Honduran forestry sector will be published on the ICF's Geoportal.
- The Union will publish on the websites of the EU Delegation in Honduras and of the European Commission information on the JIC (see 4.1), the text of this Agreement (see 4.2) and a link to the ICF's webpage.

*Other means of dissemination*

- Multi-stakeholder platforms,
- public meetings,
- press conferences,
- video films and
- radio and television.

## **6. INFORMATION FROM OTHER STAKEHOLDERS**

In the interests of transparency, public institutions, NGOs, private development organisations and projects that carry out activities related to the forestry sector should set up coordination mechanisms with the ICF to facilitate public access to information on this Agreement and the work to improve governance in the forestry sector through their websites and the ICF's website. Moreover, the public should also be informed of the activities of these organisations through a page on the ICF's official website.

Communication mechanisms must be improved so that the ICF is informed of any support relating to the forestry sector and involving the Union when it is provided by other institutions or organisations. To achieve this, the Parties agree to organize regular coordination meetings between the ICF and the EU Delegation in Honduras.

## **Annex X**

### **Joint Implementation Committee**

Pursuant to Article 19 of this Agreement, the Parties shall establish a monitoring and decision-making body called the 'Joint Implementation Committee' (JIC). The JIC shall be responsible for implementing and overseeing this Agreement, including management of the independent audit. The JIC shall also facilitate dialogue and exchanges of information between the Parties. The formation and composition of the JIC shall reflect the various stakeholders in the Honduran forestry sector: the public and private sectors, civil society, the Indigenous and Afro-descendant Peoples of Honduras, communities and others, where applicable.

In particular, the JIC shall:

#### **(a) As regards the management of this Agreement:**

1. Publish a yearly report on the implementation of this Agreement in accordance with Annex IX.
2. Following the evaluation of the functioning of the Honduran Legality Assurance System (LAS) for timber products and based on the assessment criteria outlined in Annex VII, recommend the date on which the FLEGT licensing scheme will start operating.
3. Draw up, review, update and validate documents and implementing arrangements for this Agreement, such as the LAS verification manual, guidelines for the implementation for supplementary and support measures, and the implementation schedule of this Agreement.
4. Based on these documents and implementing arrangements, for which it is responsible, review progress towards achieving the objectives and deadlines set for the different actions in this Agreement and its implementation, and propose and adopt measures aimed at improving the functioning of this Agreement.
5. Analyse and record all necessary amendments to this Agreement. The JIC will also analyse, at least once every two years, any revisions or updates to this Agreement and its Annexes that may be needed to take into account any relevant changes to the regulatory, administrative and institutional frameworks in Honduras.
6. Address matters of concern raised by either of the Parties and resolve any conflicts that may arise in the course of the implementation of Article 11 of this Agreement.
7. Address matters of concern raised by either of the Parties and resolve any conflicts that may arise in the course of the implementation of Article 24 of this Agreement.
8. Publish reports and memos to make the work of the JIC transparent.

#### **(b) As regards the monitoring and assessment of this Agreement:**

1. Agree on a method for monitoring and evaluating the implementation and impact of this Agreement.
2. Monitor overall progress on the implementation of this Agreement, including the functioning of the LAS.
3. Conduct regular joint missions to review the effectiveness of this Agreement and its impact, based on the information available.



4. Monitor the market situation and draft regular reports on it, commissioning studies as necessary and recommending measures to be taken in response to intelligence reports on the state of the market in timber products.
5. Assess the social, economic and environmental impact of this Agreement, in accordance with relevant good practices and criteria to be agreed by the Parties and address any problems raised by this assessment.
6. Identify the difficulties associated with implementation of this Agreement and suggest suitable measures to address them.

**(c) As regards the independent audit of this Agreement:**

1. Issue a 'no objection' decision for the appointment of the independent auditor selected by the Parties and the renewal of its contract, where applicable.
2. Approve the independent auditor's manual of audit procedures and work timetable in accordance with Annex VI .
3. Review and approve the reports from the organisation acting as the independent auditor, examine any complaints on the functioning of the FLEGT licensing system, and manage the implementation of the recommendations on the territory of each Party.
4. Request specific reports in addition to the independent audit, should any be required.
5. Examine complaints about the work of the independent auditor and agree on the measures to be adopted.
6. Publish LAS reports, in accordance with Annexes VI and IX.
7. Monitor, where applicable, measures taken to address the problems identified by the independent auditor.

**(d) As regards involving stakeholders in implementing and monitoring this Agreement:**

1. Take appropriate measures to encourage the participation of stakeholders in the implementation of this Agreement.
2. Propose and follow up recommendations on capacity-building requirements for the successful implementation of this Agreement and, if applicable, on the need to increase capacity for and participation by the private sector, civil society, local communities and the Indigenous and Afro-descendant Peoples of Honduras in the implementation of this Agreement in compliance with the laws and regulations relating to forest management in Honduras.
3. If necessary, establish working groups or other subsidiary bodies for areas of work requiring specific expertise or feedback from stakeholders.
4. Approve the JIC rules and monitor their implementation.